

mistral

12-inch High Velocity DC Stand Fan

MHV9812DRW

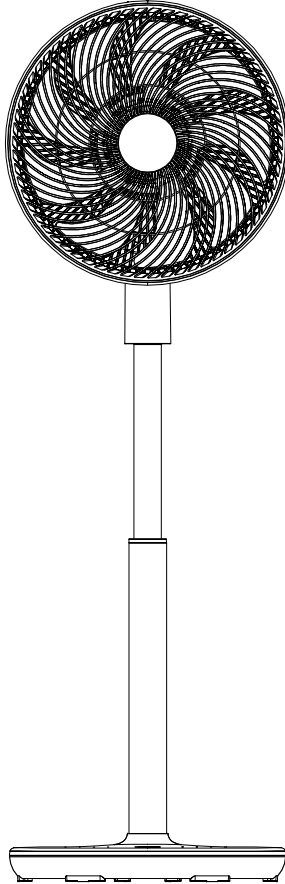

HIGH VELOCITY FAN

Please read this instruction manual thoroughly before operating and keep it for future reference

IMPORTANT SAFETY INSTRUCTIONS

1. Read all instruction carefully and keep this manual for future reference.
2. This appliance can be used by children aged from 8 years and above and persons with reduced physical, sensory or mental capabilities or lack of experience and knowledge if they have been given supervision or instruction concerning use of the appliance in a safe way and understand the hazards involved. Children shall not play with the appliance. Cleaning and user maintenance shall not be made by children without supervision.
3. Do not let the appliance touch any hot surfaces.
4. To avoid electric shock, do not place the cord, the plug or the appliance in water or other liquids.
5. Close supervision is necessary when the appliance is used by or near the children.
6. Unplug the plug outlet when not in use and before cleaning.
7. Do not operate the appliance with a damaged cord or plug or after the appliance malfunctions or has been damaged in any manner. Return the appliance to our customer service centre for examination.
8. Do not let the cord hang over the edge of a table or counter or touch hot surfaces. Do not place the appliance on an unsteady or cloth covered surface.
9. Please check the power cord & the plug firstly to see if they are normal , and check the body to see if there is any a crack or damages. If there is any abnormal, please call the customer service hotline for assistance.
10. When you are going to move the fan or not in use, please cut off the power and unplug the plug.
11. Do not use the fan in the area at high humidity, temperature higher than 40°C or dusty area.
12. Do not insert the fingers or another objects into the fan during operation. Especially take care of the children.
13. Please do not blow to the elder, the children or the patient directly for a long time.
14. Do not spray any detergent such as bug or mosquito killer into the fan to prevent it from damages to the plastic material.
15. The appliance is for household use only. Do not use at outdoors or for any commercial or industrial purpose.
16. This appliance is not intended for use by persons (including children) with reduced physical, sensory or mental capabilities, or lack of experience and knowledge, unless they have been given supervision or instruction concerning use of the appliance by a person responsible for their safety.
17. Children should be supervised to ensure that do not play with the appliance.
18. Always disconnect the mains power, before any user maintenance.
19. If the supply cord is damaged, it must be replaced by the sole distributor, its service agent or similarly qualified persons in order to avoid a hazard.
20. Please ensure that the fan is switched off from the supply mains before removing the guard.

- 21. Only use on 220-240V AC, 50/60Hz power supply.
- 22. Do not operate the fan in the presence of explosive and/or flammable fumes.
- 23. Do not place the fan or any parts near an open flame, cooking or other heating appliance.
- 24. Do not hang or mount fan on a wall or ceiling.
- 25. Do not operate if the fan housing is damaged.

INTRODUCTION OF PARTS

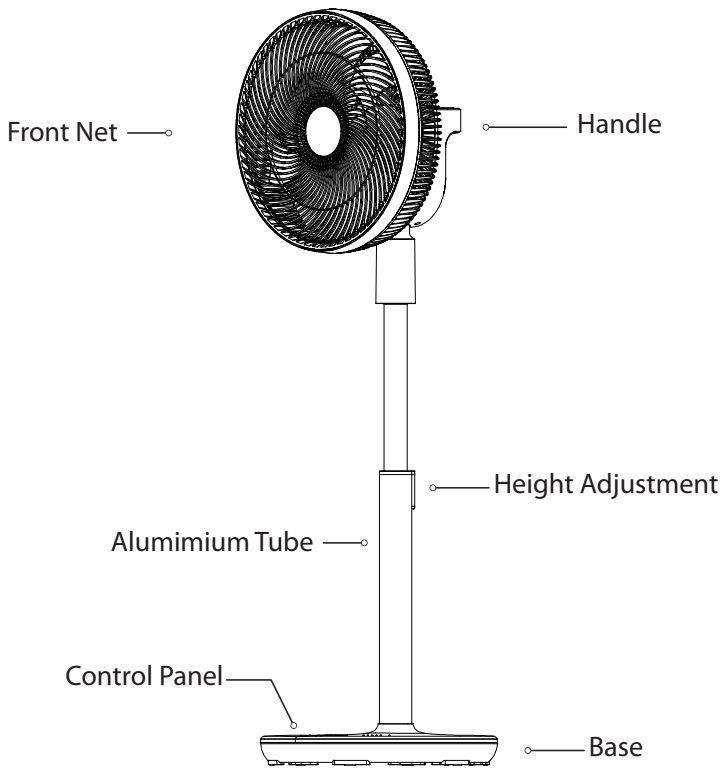

ASSEMBLY GUIDE

Before You Begin:

Ensure all parts are included and you have the provided screwdriver tool.

1. Assemble the Base

- Insert the column into the base and connect it securely.
- Use the provided screwdriver to fix the hex screw into the hole at the center of the base.

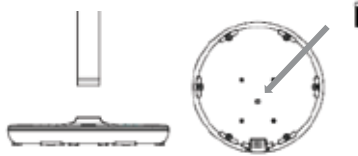

2. Attach the Rear Guard.

- Align the arrow on the rear guard with the arrow on the motor unit (both arrows pointing upward).
- Secure the rear guard fixing nut by rotating it clockwise until tight.

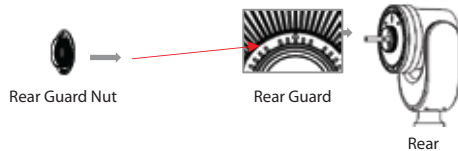

3. Install the Fan Blade.

- Place the fan blade onto the protruding shaft of the assembled head section.
- Attach the blade fixing nut and rotate it counterclockwise until fully tightened.

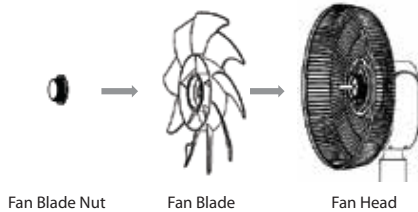

4. Secure the Front Guard.

- Position the front guard in place over the rear guard and rotate it to the locked position.
- Once aligned, use the provided screwdriver to tighten the cross screw at the bottom, securing both guards together.

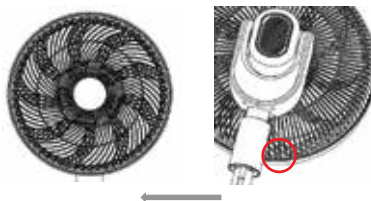

OPERATING INSTRUCTIONS

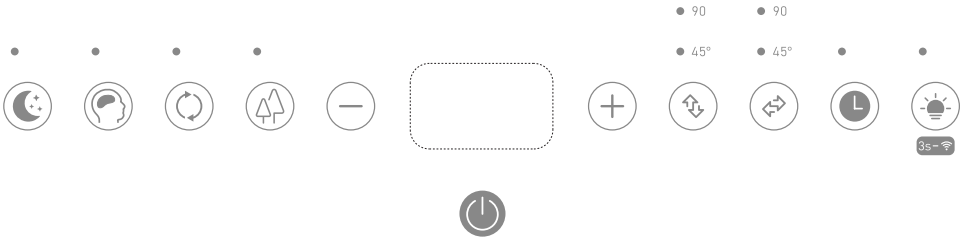

Power

1. Check the household voltage to ensure it matches the appliance's rated specification. Be sure to plug into a 220-240V~, 50Hz/60Hz outlet.

Power on/off

Press key, power on, product starts at speed one with display.

Press key again, power off, product stop working.

Speed adjust

Product has 12 speeds.

Press key "—" reduce speed.

Press key "+" increase speed.

When you chose a speed, the number will show in the display window.

OSC (up and down)

Press the key, the product will oscillate up and down by automatic 45/90 degrees.

Press again, the oscillation will stop.

OSC (left and right)

Press the key, the product will oscillate left and right by automatic 45/90 degrees.

Press again, the oscillation will stop.

Sleep Mode

Press the key to enter Sleep mode.

Product run at reduce wind speed of one speed per 30mins in the selected speed.



Eco Mode

Press the key to enter Eco mode.

Product run at the current set wind speed will change by ± 1 speed when the indoor temperature is detected within $\pm 2^\circ\text{C}$.



Cycle Mode

Press the key to enter Cycle mode.

Product run at 12 speed with left & right OSC 90 degrees and up & down OSC 90 degrees.



Naturel Mode

Press the key to enter Naturel mode.

Product run according to a fixed wind speed sequence program, with a mixed combination of high, medium and low wind speeds.

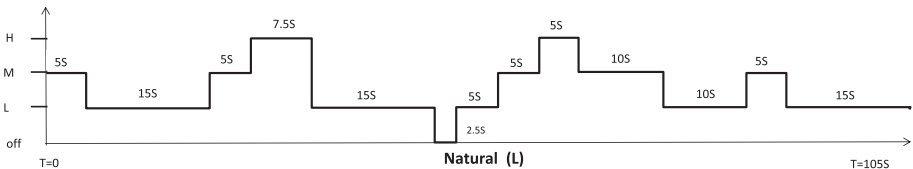
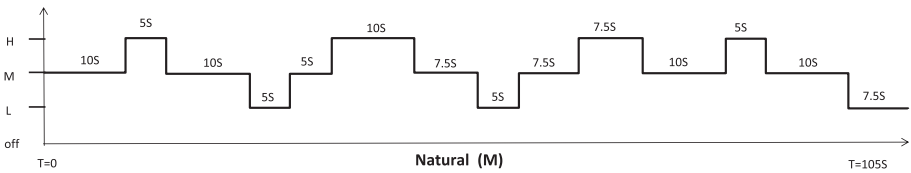
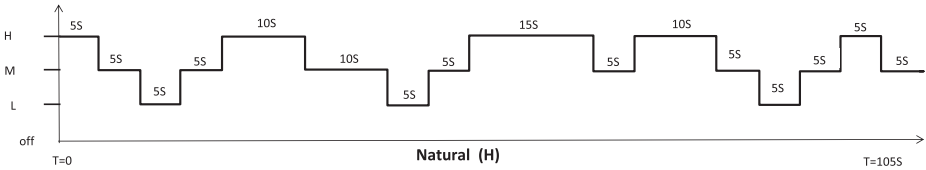



Timer

Product has been setting on 1H/2H/3H/4H/5H/6H/7H/8H/9H/10H/11H/12H.
Press the key, the LED display window will show the timer hours number.



Lighting and WIFI

Press the key with short time, the lighting will turn on.
There are 2 lighting level to choose.
Press the key long time with 3 seconds to enter the WIFI connection.
(The details should reference the WIFI guide/manual)

Remote control

The remote control has the same function as the control panel.
Please pull the adapter out if do not use for long time.

WIFI OPERATION

Operation

Steps	Items	New Account	Re-install App (Registered Before)
1	Download and Install the App	Yes	Yes
2	Active App	Yes	Yes
3	Registration Account	Yes	No
4	Login	Yes	Yes
5	Add Device to Control	Yes	Registered Device will remain.

This device complies with part 15 of the FCC Rules. Operation is subject to the following two conditions:

- (1) This device may not cause harmful interference, and (2) this device must accept any interference received, including interference that may cause undesired operation.
- Any Changes or modifications not expressly approved by the party responsible for compliance could void the user's authority to operate the equipment.

Note:

- This equipment has been tested and found to comply with the limits for a Class B digital device, pursuant to part 15 of the FCC Rules. These limits are designed to provide reasonable protection against harmful interference in a residential installation. This equipment generates uses and can radiate radio frequency energy and, if not installed and used in accordance with the instructions, may cause harmful interference to radio communications. However, there is no guarantee that interference will not occur in a particular installation. If this equipment does cause harmful interference to radio or television reception, which can be determined by turning the equipment off and on, the user is encouraged to try to correct the interference by one or more of the following measures:
 - Reorient or relocate the receiving antenna.
 - Increase the separation between the equipment and receiver.
 - Connect the equipment into an outlet on a circuit different from that to which the receiver is connected.
 - Consult the dealer or an experienced radio/TV technician for help.
 - The distance between user and device should be no less than 20cm.

Module specification and basic information

1. Minimum specifications on a Smart phone:
 - Android 5.0 version or higher
 - IOS 10.0 version or higher

2. Basic parameters for Wi-Fi:

Parameters	Details
Network Frequency	2.400 - 2.500GHz
Standards of WLAN	IEEE 802.11 b/g/n(channels 1-14)

Download and Install the App

- For Android smart phone, open the Google "Play Store" on your smart phone and search "mayer home", download and install the APP.
- For IOS smart phone, open the Apple "App Store" on your smart phone and search "mayer home", download and install the APP.



Note

- Please enable the permissions of Storage / Location / Camera / Wi-Fi / Bluetooth for this APP when installing. Otherwise it will have some problems when operating.

Registration

4. Enter your E-mail address.
5. Tap the button "Get Verification Code".
6. Enter the verification code you received from E-mail.
7. Set the Password with 6-20 characters including characters and numbers.
8. Tap "Done".



Log in

1. If you already have account, tap "Log in with Existing Account".
2. Enter your registered account and password.
3. Tap "Log in" button.

Registration

1. If you don't have any account please tap button "Register".
2. Read the "Privacy Policy" and tap "Agree".

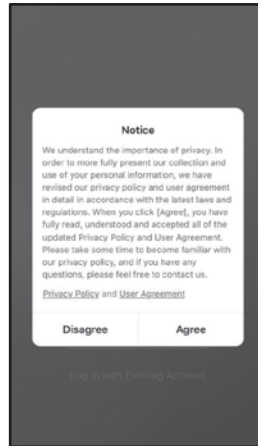

3. Tap ">" and choose the country.
 - Search the country or slide the screen up/down to find and choose the country.

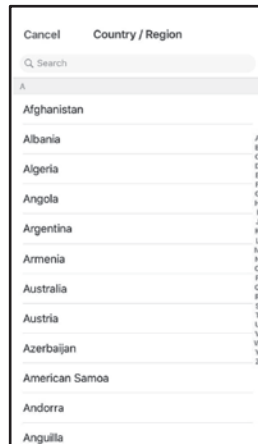
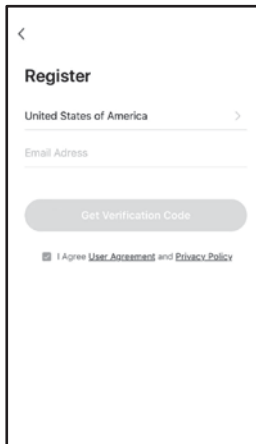

Forgot the password

If you forgot the password or you want to reset the password, operate as below:

1. Tap "Forgot password".
2. Enter your account(E-mail address) and tap button "Get verification code".
3. Enter the verification code received by your E-mail.
4. Set the new password and tap button "Done".

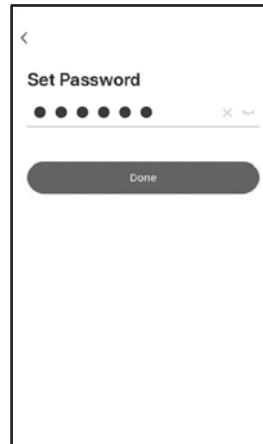
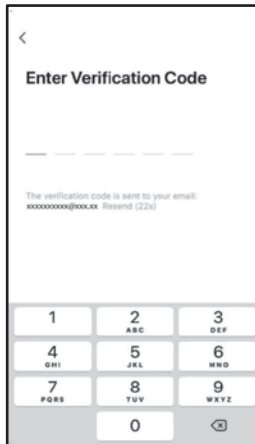
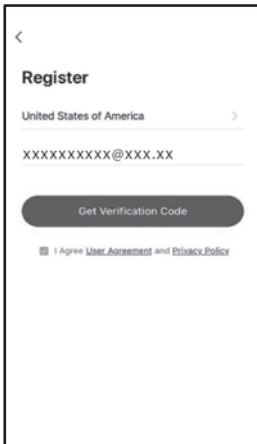

To connect to Alexa

Method 1: Operation in the App that needs to be bound (using mayer home as an example here)

1. Download the Alexa App and register/login to your Amazon account.
2. Open the App that needs to be bound, go to Home - Me - Third-party Voice Services - Alexa.
3. Click "Sign in With Amazon" and the Alexa App will be launched. Click "LINK" to complete the binding.

Method 2: Operation in the Alexa App

1. Download the App that needs to be bound and register/login to your account.
2. Open the Alexa App and click "More" in the lower right corner.
3. Click "Skills & Games" and then click the search button in the upper right corner. Enter the name of the skill you need to bind, using mayer home as an example here.
4. Click the mayer home skill to enter the skill details page (ENABLE TO USE), click "Agree and link", and return to the Alexa App.
5. Click "CLOSE" and then click "DISCOVER DEVICES" to complete the binding.

For more information on how to connect to Alexa using mayer home app,

Please scan the QR Code

https://support.tuya.com/en/help/_detail/K9psi68xxmmg0



To Connect to Google Home

Method 1: Use Google Home app to start linking

1. Open the Google Home app and tap + in the top left corner of the homepage.
2. Select Set up device > Works with Google.
3. Tap the Search icon in the top right corner of the page, and search by mayer home app name.
4. Tap the searched result and then Continue. The Google Home app will wake up the mayer home app. Tap Agree and link and wait to the end of loading. This way the mayer home app is linked with the Google Assistant.

Method 2: Use mayer home app to start linking

1. If the mobile phone has the Google Home app installed, open the mayer home app and tap Me on the tab bar.
2. In the Third-Party Voice Services section, select Google Assistant > Link with Google Assistant to wake up the Google Home app.
3. Tap Continue to return to the mayer home app
4. Tap Agree and link to access the Google Home app. This way the mayer home app is linked with the Google Assistant.



For more information on how to connect to Google Home using mayer home app,

Please scan the QR Code or refer to the following link:



<https://developer.tuya.com/en/docs/iot/googlehomeguide?id=K9j6yqpeqzzgp>

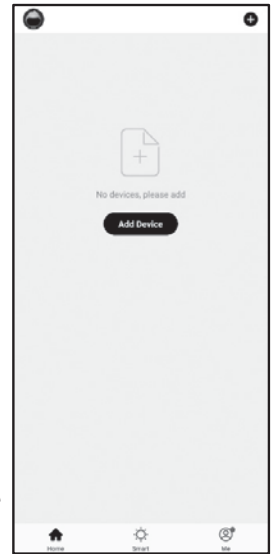

Set up your air circulator

- Choose from the options available to allow for easy pairing and use. Bluetooth connection has also been activated for this appliance, which will aid in the pairing process, providing a higher success rate when pairing.
- Ensure the mobile device is connected to a home Wi-Fi network.
 - The air circulator must be on standby mode.
Once on standby, the “” symbol will flash fast on the display panel. The air circulator is now ready to connect.
 - Log into your Mayer Home app account and stay on the “Home” page. To add the air circulator to the list, touch ‘Add Device’ or the “” symbol found in the top right-hand corner of the screen.
Follow the prompts in the app.
 - If the connection is successful, the air circulator will appear in the main page of the app and the “” symbol light on the air circulator will illuminate.



If connection is unsuccessful, touch and hold the “” button for 5 seconds until the “” symbol is flashing slowly. Follow the prompts in the app to connect in a different mode.

WIFI TROUBLESHOOTING

Troubleshooting Guide for Amazon Alexa and Google Home / Assistant	
Problem	Analysis of Cause
Why is Amazon Alexa or Google Home/Assistant not responding to my voice commands.	Check the internet connection.
	Restart your device & mobile phone.
	Restart your modem and router.
	Make sure your Amazon Alexa or Google-enabled device or mobile phone is in Wi-Fi range.
	When you are giving a command to Amazon Alexa or Google Home/Assistant make sure you are clear and there is no unwanted noise in the background.
	While the voice assistant is always on in the background, only an activation phrase will allow for the voice assistant to start. registering the commands being relayed. The activation phrase depends on the application being used; For Amazon Alexa, use “Alexa”, while “OK Google” is for Google Home/Assistant.
	Ensure your voice is clear and distinct to allow the assistant to accurately record and process the command.
Ask direct questions. Refer to the commands list for recommended commands.	

VOICE ASSISTANTS

The mayer home comes with the added features of voice assistance, allowing you to control your air circulator using your voice by linking your mayer home app with Amazon Alexa and Google Home/Assistant.

To link your mayer home app account with either Amazon Alexa or Google Home / Assistant, refer to under Me > Third-Party Voices Services > View more ways to link.

Important

- The recommended voice commands to operate the appliance's functions differ between Amazon Alexa and Google Home/Assistant as listed. Variations of these commands may also be recognised, however, if a command fails, check against the recommended voice command.

Note

- To control the air circulator using the Amazon Alexa or Google Home/Assistant app, the air circulator must be plugged in to an active power outlet and on standby mode.

Voice Control with Amazon Alexa or Google Home / Assistant

- Before you can voice control your mayer home with Amazon Alexa or Google Home / Assistant, you need to link the mayer home account to the Amazon Alexa or Google Home / Assistant app as per instructions.

Supported Settings	Voice Command (Alexa)	Voice Command (Google Home)
Power	"turn on the <device name>."	"OK Google, turn on <device name>."
	"turn off the <device name>."	"OK Google, turn off <device name>."
Mode	"set the mode to Nature/sleep/smart/Normal/Circulation "	"set the <device name> to Nature/Smart/Normal/Sleep/Circulation"
	"set the mode on the <device name> to Nature/sleep/smart/Normal/Circulation "	"set Mode on <device name> to Nature/Smart/Normal/Sleep/Circulation"

Fan Speed	"set the <device name> fan speed/speed to (1-12)"	"set the <device name> to (1-12)"
	"set the fan speed/speed on the <device name> to maximum"	"set <device name> fan speed to (1-12)"
	"decrease the fan speed/speed on the <device name> by (1-12)"	
	"what's the <device name> fan speed/speed?"	
	"turn up the <device name> fan speed/speed"	
Horizontal Swing (Oscillation)	"set the Horizontal Swing/Oscillation to 90 degree/cancel/stop/45 degree"	"set the <device name> to 90 degree/Cancel/Stop/45 degree"
	"set the Horizontal Swing/Oscillation on the <device name> to 90 degree/cancel/stop/45 degree"	"set Horizontal Swing/Oscillation on <device name> to 90 degree/Cancel/Stop/45 degree"
Vertical Swing (Up-Down Oscillation)	"set the Vertical Swing to Cancel/stop/45 degree/90 degree"	"set the <device name> to 45 degree/90 degree/cancel/stop"
	"set the Vertical Swing on the <device name> to Cancel/stop/45 degree/90 degree"	"set Vertical Swing on <device name> to 45 degree/90 degree/cancel/stop"
Count Down (Timer)	"set the count down to 1 hour / 2 hour / 3 hour / 4 hour / 5 hour / 6 hour / 7 hour / 8 hour / 9 hour / 10 hour / 11 hour / 12 hour / cancel / off"	"set the <device name> to 1 hour / 2 hour / 3 hour / 4 hour / 5 hour / 6 hour / 7 hour / 8 hour / 9 hour / 10 hour / 11 hour / 12 hour / cancel / off"
	"set the count down on the <device name> to 1 hour / 2 hour / 3 hour / 4 hour / 5 hour / 6 hour / 7 hour / 8 hour / 9 hour / 10 hour / 11 hour / 12 hour / cancel / off"	"set count down/timer on <device name> to 1 hour / 2 hour / 3 hour / 4 hour / 5 hour / 6 hour / 7 hour / 8 hour / 9 hour / 10 hour / 11 hour / 12 hour / cancel / off"
Moodlight	"set the Moodlight/light to dim/brighten/cancel/off"	"set the <device name> to dim/cancel/stop/brighten"
	"set the Moodlight/light on the <device name> to dim/brighten/cancel/off"	"set moodlight/light on <device name> to dim/cancel/stop/brighten"

TIPS for Amazon Alexa and Google Home/Assistants

- Configure your Amazon Alexa or Google Home/Assistant compatible devices with the "Amazon Alexa" or "Google Home/Assistant" app if using, or simply download onto your phone.
- You will find your device listed as the Mistral product name in your myer home app account. Tap on the device in the app to rename your device for more convenient voice commands, e.g. "Circulator Living Room" or give it a name, e.g. "Kenny".
- Training your voice assistant - Voice Match - Teach your assistant to recognise your voice. This isn't training it to understand English, but rather to recognise your voice as belonging to you. You can do this by going to the Settings menu in the voice assistant app on your phone.
- Routines - Amazon Alexa and Google Home/Assistant allow you to combine multiple actions in one voice command, to create a Routine, tap on the 'Routines' option via settings and follow the steps.
- Ensure the primary language is set to English (United States) for all apps.

CLEANING AND MAINTENANCE

Cleaning and Storage Method

1. When cleaning or maintaining the product, be sure to unplug the product and allow the product to cool down before cleaning.
2. Never disassemble the product when cleaning.
3. Do not use water directly to clean (water entering the motor may cause serious damage to the product)
4. Use a soft brush to cleanly remove any dust or foreign substances inside and outside the main body and grill.
5. Clean the main body and grill gaps with a wet towel that has sufficiently wrung out the moisture.
6. After cleaning, dry completely in a well-ventilated place before using.
7. Do not spray pesticides or flammable sprays, or wipe with highly flammable/explosive substances such as benzene, thinner, or alcohol.
8. Clean the product regularly (approximately 1-2 times a month)
9. If the product is not used for a long period of time, clean it as above, cover it with a plastic cover, and store it in a cool, dry place.



Disposal

The product must not be disposed of via normal household waste after its service life, but must be taken to a collection station for recycling of electrical and electronic devices. The symbol on the product, the operating instructions or the packaging indicates such disposal procedures. The materials recyclable in accordance with their respective symbol. By means of re-use, material recycling or any other form of recycling old appliances, you are making an important contribution to the protection of our environment.



Keep the original packaging in a safe place so that you may use it in the event that transportation or shipping of the product becomes necessary.

Warranty & Customer Service

SCAN FOR



e-Warranty

e-Warranty Registration at www.mayer.sg

MAYER MARKETING PTE LTD

Customer Service Hotline: 6542-8383 (Mon - Fri 9:00am to 5:00 pm)

Service Centre Operating Hours:

Mon - Fri: 9:00am to 5:00pm

Sat: 9:00am to 12:00pm

Closed on Sunday & Public Holidays

71 Ubi Crescent, #06-02, Excalibur Centre, Singapore 408571.

For more information on warranty policy, please visit:

<https://mayer.sg/pages/warranty-return-and-exchange-policy>