

mayer

60cm Built-in Electric Oven

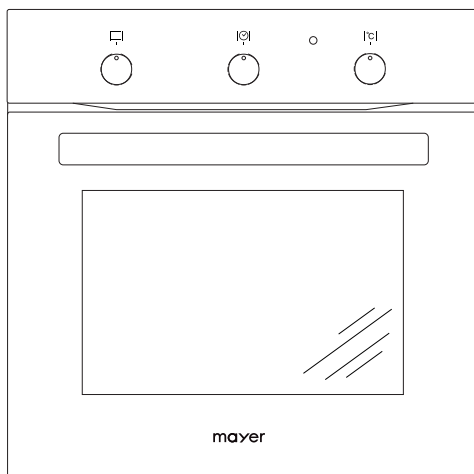

MMDO9

Instruction Manual

Warning

- 1) Read instructions carefully before installing or using this product to operate your appliance safely and correctly. Retain the instruction manual and installation instructions for future use for subsequent users.
- 2) The images shown in these instructions are for guidance only.
- 3) This appliance was designed and created exclusively for standard household use. Do not use it for commercial or industrial purposes, or for any other purpose than for which it was designed.
- 4) Check the appliance for damage after unpacking it. Do not connect the appliance if it has been damaged in transport.
- 5) Only a licensed professional may connect appliances without plugs. Damaged caused by incorrect installation or connection is not covered under warranty.
- 6) The appliance should be supervised during operation.
- 7) The appliance is not to be used by persons (including children) with reduced physical, sensory or mental capabilities, or persons with a lack of experience or knowledge, without supervision or instruction by a person responsible for their safety who understands the safety hazards.
- 8) The appliance should not be played with, or played around.
- 9) The appliance should only be used indoors.
- 10) Do not modify, or attempt to modify any of the characteristics of this appliance. This poses a safety risk.
- 11) Accessible parts may become hot during use. Children or persons with reduced physical, sensory or mental capabilities should be kept away from the appliance. Never touch the interior surfaces of the cooking compartment or the heating element of the appliance when the appliance is in use.
- 12) Never place tin foil directly in contact with the oven floor as the buildup of heat may damage the enamel.
- 13) Do not cover the cooking compartment floor with any sort of foil or greaseproof paper. Do not place ovenware on the cooking cavity floor if a temperature of over 50 deg C has been set. Doing so will cause heat to accumulate and cooking time will be affected, and the oven floor may be damaged.
- 14) Over an extended period, moisture in the cooking cavity may lead to corrosion. Allow the cooking cavity to dry after use. Do not keep moist foods in the closed cooking cavity for extended periods of time. Do not store food in the cooking cavity.
- 15) The oven must be turned off when cleaning inside the oven.
- 16) Do not use harsh or abrasive cleaning agents, cleaning agents with a high alcohol content, hard scouring pads or cleaning sponges, high pressure cleaners or steam cleaners to clean the appliance. Do not attempt to clean the appliance while it is still hot.
- 17) Do not leave the oven door open for the purposes of cooling the oven down. The oven has an automatic cooling system. Ensure that the oven door is fully closed before operations. Even if the oven is only left open a crack, the front of nearby furniture may become heat damaged over time.

Warning

- 18) If the door seal is very dirty, the appliance door may no longer close properly during operation. Always keep the seal clean.
- 19) Only use oven safe cookware with the appliance. Mayer Marketing Pte Ltd is not liable for damages from improper product usage.
- 20) Alcoholic vapours may catch fire in the hot cooking compartment. Never prepare food containing large quantities of drinks with a high alcohol content in the appliance.
- 21) Open the appliance door with care – do not place items weighing over 15kg on the open appliance door.
- 22) After using your oven, ensure that all controls are in their 'stop' position.
- 23) To prevent overheating, do not install this appliance behind a door. Ensure the area of installation is well ventilated.
- 24) Do not carry or hold the appliance by the door handle. The door handle cannot support the weight of the appliance and could break.

DEAR CUSTOMER,

The oven is exceptionally easy to use and extremely efficient. After reading the instruction manual, operating the oven will be easy.

Before being packaged and leaving the manufacturer, the oven was thoroughly checked with regard to safety and functionality.

Before using the appliance, please read the instruction manual carefully. By following these instructions carefully you will be able to avoid any problems in using the appliance.

It is important to keep the instruction manual and store it in a safe place so that it can be consulted at any time.

Please become familiar with these recommendations before installing and using your oven. They were written for your safety and the safety of others.

Caution!

Do not use the oven until you have read this instruction manual.

The oven is intended for household use only.

The manufacturer reserves the right to introduce changes which do not affect the operation of the appliance.

TABLE OF CONTENTS

Safety instructions.....	3
How to save energy.....	5
Description of the appliance.....	7
Specifications of the appliance.....	8
Installation.....	9
Operation.....	11
Cleaning and maintenance.....	15
Operation in case of emergency.....	19
Baking in the oven-practical hints.....	20
Technical data.....	25

SAFETY INSTRUCTIONS

Safety Instructions

- 1) Ensure that the appliance is installed to a grounded power source.
- 2) A dedicated power circuit is recommended for the appliance. Additional electrical appliances on the same circuit may exceed the current (amperage) rating for the circuit leading to the circuit breaker tripping or fuse failing.
- 3) Avoid the use of an extension cord, which may overheat and cause a fire.
- 4) The appliance must be installed by a qualified professional in compliance with the instructions provided. Mayer Marketing Pte Ltd is not liable for damages caused by improper installation or operation of the appliance.
- 5) The appliance should not be connected to a power supply during servicing or if not in use for an extended period.

This is a classified electrical appliance. As with any electrical appliance, basic precautions should be followed in order to reduce the risk of harm to self, others and property.

- The appliance becomes very hot during operation. Never touch the interior surfaces of the cooking cavity, the heating elements and cooking accessories within the appliance during operation. Make use of heat protection before interacting with the oven cavity when hot.
- Loose food remnants, fat, grease and meat juices may catch fire. Before using the appliance, ensure that the cooking cavity, heating elements and accessories are clean.
- In case of fire or smoke within the cavity, **do not** open the appliance door as this may cause the fire to spread into your home and cause severe burns. Immediately switch off the appliance and unplug it from the mains, or switch off the circuit breaker in the fuse box. Leave the fire to burn out on its own. If fire persists, call the fire department immediately and get to safety.
- This appliance is not intended for use by persons (including children) with reduced physical, sensory or mental capabilities or lack of experience and knowledge without supervision and instruction by a person responsible for their safety and who understands the associated hazards.
- Ensure that small items of household equipment, including connection leads do not touch the hot appliance as the insulation material of such equipment are usually not resistant to such high temperatures.
- If the supply cord is damaged, it must be replaced by a service agents of Mayer Marketing Pte Ltd or similarly qualified persons. Mayer Marketing Pte Ltd is not liable for damages as a result of improper installation or servicing of the appliance.
- The appliance must be disconnected from the power supply whenever servicing or installation work is being carried out.
- Do not use the appliance in event of a technical fault. Faults should be serviced by service agents of Mayer Marketing Pte Ltd. Contact information for the service centre is available on the back of this instruction manual.

SAFETY INSTRUCTIONS

- The panels adjacent to the oven should be made of heat resistant material.
- Cabinets with a veneer exterior must be assembled with glues which can withstand temperatures of up to 100 deg C.
- Keep combustible materials such as curtains, drapes, linens, paper etc. out of contact away from the appliance when in operation. Do not use this appliance in areas where gasoline or other flammable liquids and their associated vapours may be present.
- Ensure the appliance is installed in a well ventilated area.
- The unit's power cord must be connected to a properly grounded and protected 220 – 240V electrical outlet. Always use ground fault protection where required by the electrical code.
- Do not operate any appliance with a damage cord or plug or after the appliance malfunctions, has been dropped, or damaged in any manner. Contact the authorized service centre to arrange for servicing.
- Use this appliance only as described in this manual.
- Water in a hot cooking cavity may create hot steam. Never pour water onto the hot cooking cavity or on accessories within the hot cooking cavity.

HOW TO SAVE ENERGY

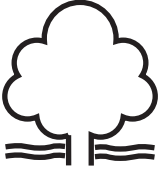

Using energy in a responsible way not only saves money but also helps the environment. So let's save energy! Here are some ways to do so:

! Open the appliance door as infrequently as possible when the appliance is in use.

! Switch off the oven in good time and make use of residual heat.

For long cooking times, switch the appliance 5 to 10 minutes before finishing cooking. This saves up to 20% on energy.

! Only use the oven when cooking larger dishes.

Meat of up to 1 kg can be prepared more economically in a pan on the cooker hob.

! Open the appliance door as infrequently as possible when the appliance is in use.

Important! When using the timer, set appropriately shorter cooking times according to the dish being prepared.

! Leave frozen food to defrost before cooking it in the cooking cavity.

! Do not install the cooker in the direct vicinity of refrigerators/freezers. Otherwise energy consumption increases unnecessarily.

UNPACKING



During transportation, protective packaging was used to protect the appliance against any damage. After unpacking, please dispose of all elements of packaging in a way that will not cause damage to the environment. All materials used for packaging the appliance are environmentally friendly; they are 100% recyclable and are marked with the appropriate symbol.

Caution! During unpacking, the packaging materials (polythene bags, polystyrene pieces, etc.) should be kept out of reach of children.

DISPOSAL OF THE APPLIANCE

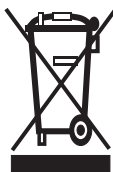

Old appliances should not simply be disposed of with normal household waste, but should be delivered to a collection and recycling centre for electric and electronic equipment. A symbol shown on the product, the instruction manual or the packaging shows that it is suitable for recycling.

Materials used inside the appliance are recyclable and are labelled with information concerning this. By recycling materials or other parts from used devices you are making a significant contribution to the protection of our environment.

Information on appropriate disposal centres for used devices can be provided by your local authority.

DESCRIPTION OF THE APPLIANCE

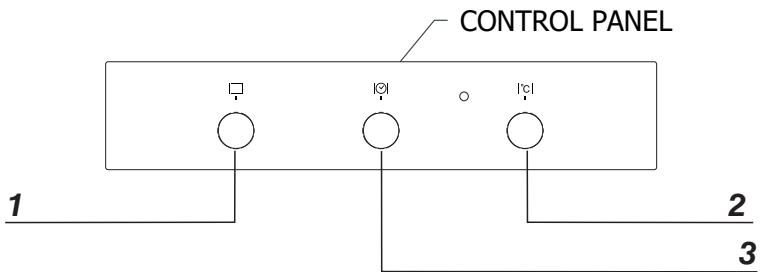
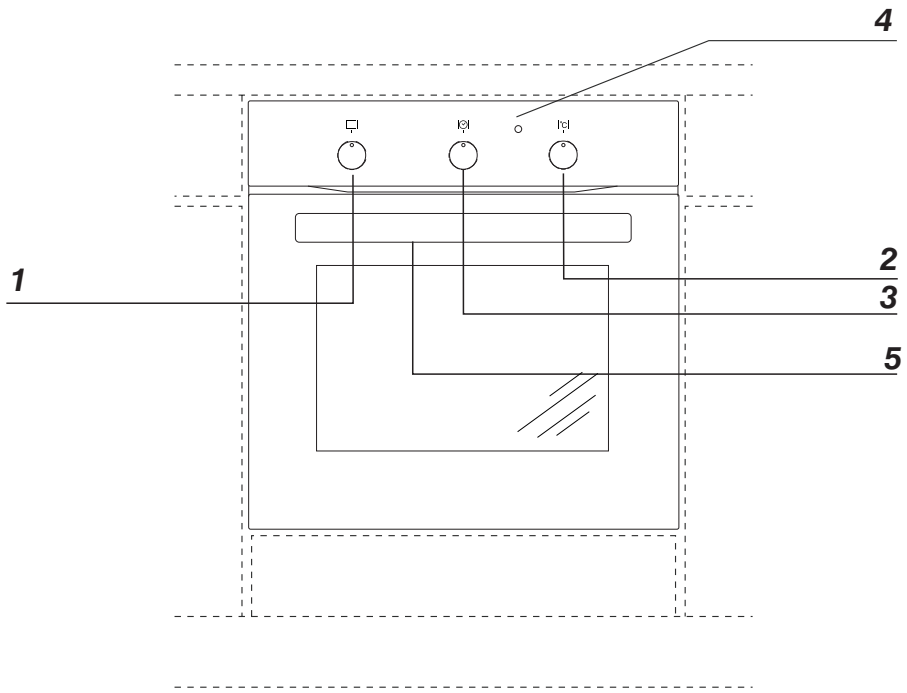

- 1 Oven function selection knob
- 2 Temperature control knob
- 3 Timer
- 4 Red temperature regulator signal light
- 5 Oven door handle

SPECIFICATIONS OF THE APPLIANCE

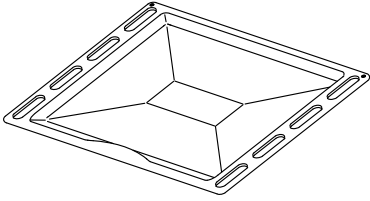

Baking tray

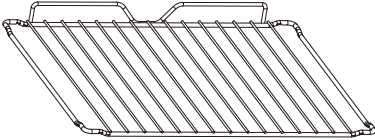

Oven shelf

INSTALLATION

! The kitchen area should be dry and well ventilated. When installing the oven, ensure easy access to all control elements.

! This is a built-in oven, and its back wall and one side wall can be placed next to a high piece of furniture or a wall. Coating or veneer used on fitted furniture must be applied with a heat-resistant adhesive (100°C). This prevents surface deformation or detachment of the coating.

! Make an opening with the dimensions given in the diagram for the oven to be fitted.

! Make sure the mains plug is disconnected and then connect the oven to the mains supply.

! Insert the oven completely into the opening without allowing the four screws in the places shown in the diagram to fall out.

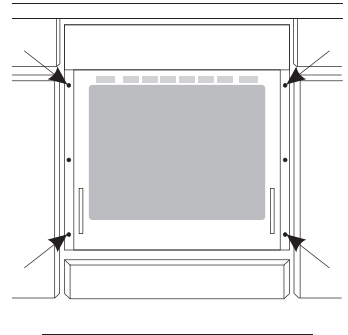
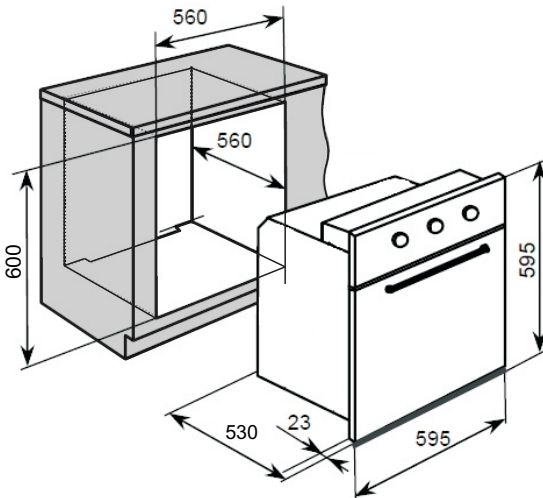
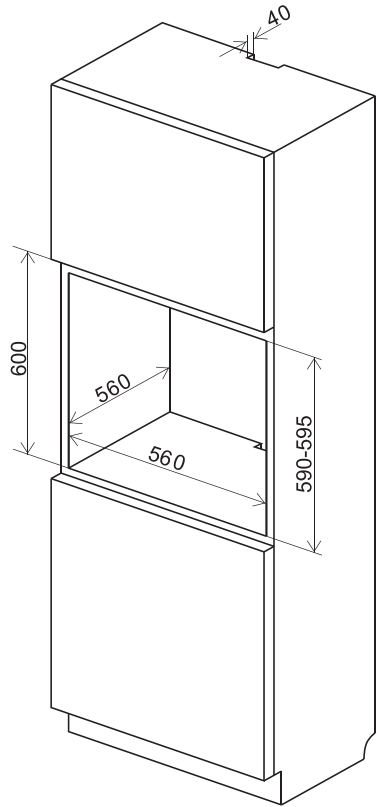

Product Dimensions

Height: 595mm
Width: 595mm
Depth: 530mm

Aperture Dimensions

600mm
560mm
560mm(min)

INSTALLATION

Electrical connection

Warning!

All electrical work should be carried out by a suitably qualified and authorised electrician. No alterations or wilful changes in the electricity supply should be carried out.

Fitting guidelines

The oven is manufactured to work with three-phase alternating current (220V–240V/50Hz). The connection diagram is also found on the cover of the connection box. Remember that the connection wire should match the connection type and the power rating of the oven.

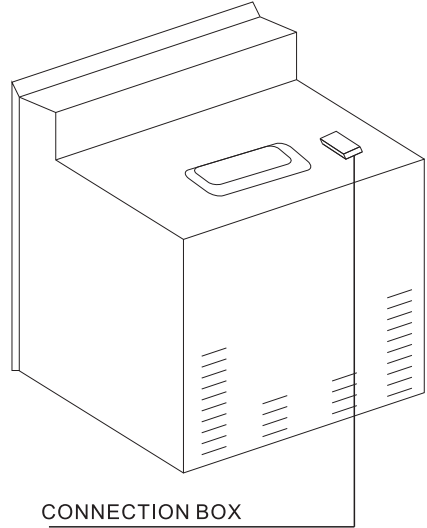

CONNECTION BOX

The connection cable must be secured in a strain-relief clamp.

Warning!

Remember to connect the safety circuit to the connection box terminal marked with \oplus . The electricity supply for the oven must have a safety switch which enables the power to be cut off in case of emergency. The distance between the working contacts of the safety switch must be at least 3 mm.

Before connecting the oven to the power supply it is important to read the information on the data plate and the connection diagram.

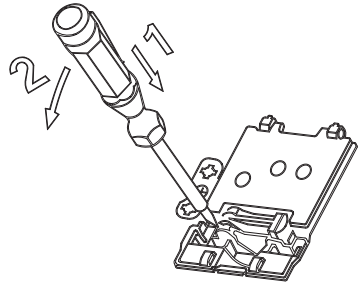

CONNECTION DIAGRAM

Caution! Voltage of heating elements 220V~240V

Caution! In the event of any connection the safety wire must be connected to the \oplus PE terminal

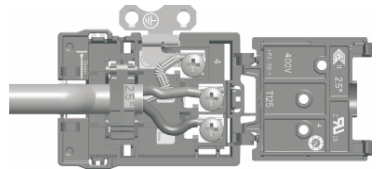

For 220V-240V earthed one phase connect on: Brown wire connect to L and blue wire connect to N, safety wire (Yellowgreen) connect to \oplus

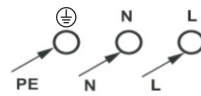

220V-240V~

OPERATION

Before first use:

! Remove packaging, clean the interior of the oven appliance.

! Take out and wash the oven fittings with warm water and a little washing-up liquid.

! Switch on the ventilation in the room or open a window.

! Heat the oven gradually, from the lowest available temperature to the highest available temperature with temperature increments being 10deg C at a time. Allow the oven to remain at each set temperature for approximately 10mins before further increasing the temperature.

Important!

The inside of the oven should only be washed with warm water and bio-degradable washing solutions.

Use a mixture of baking soda and water for a quick and easy clean.

OPERATION

Oven on and off

In order to switch on the oven you need to:

- ! Set required working conditions of the oven, its temperature and a mode of heating.
- ! Set the knob to the required position, turning it right.

► Oven functions and operation.

Natural convection oven (conventional)

The oven can be warmed up using the bottom and top heaters. Operation of the oven is controlled by the oven function knob-to set a required function you should turn the knob to the selected position.

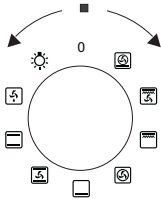

Turn the knob to set the required temperature.

When the oven has achieved the programmed temperature, the red light next to the temperature selection knob will be off. During pre-heat, the light will be on.

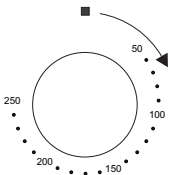

The oven can be switched off by setting both of these knobs to the position "●"/"○".

Using the minute minder

The minute minder can be used independently of an oven cooking function for a time period of up to 120 minutes.

To set the timer, turn the knob fully clockwise until it stops and then turn it back anticlockwise to the required time.

The time period that has been set will expire when the control knob reaches zero, a brief audible signal will sound.

Selecting manual operation mode

Turn the control knob clockwise to the manual operation symbol . So that the cooking time can be no limited.

To stop the oven by turning the control knob to 0.

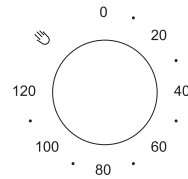

Cooking functions



Separate oven lighting

By setting the knob to this position the lighting inside the oven is switched on, e. g. use when washing the oven chamber.



Defrosting

This function allows all frozen foods to be rapidly and delicately thawed thanks to the internal fan.



Bottom and top heaters on

Heat the oven conventionally. Also known as traditional heat.



Fan, bottom and top heaters on

Conventional heat with a fan for improved heat distribution within the cooking cavity.

OPERATION



Bottom heater on

When the knob is set to this position the oven is heated using only the bottom heater. Use for e. g. final baking from the bottom.



Central element with fan On

This cooking mode allows homogenous distribution of the heat inside the oven, making it possible to cook several items of food at the same time.



Combined grill (Grill and the top heater)

When the "combined grill" is active it enables grilling with the grill and with the top heater switched on at the same time. This function allows a higher temperature at the top of the cooking area, which causes more intense browning of the dish and permits larger portions to be grilled.



Fan & combined grill

When the knob is turned to this position, the oven activates the combined grill and fan function. this function allows the grilling process to be speeded up.



Bottom + circular + fan

A crisp underside to pizza bases, quiches and pastry cases can be achieved by activating the intensive hot air setting. No need to preheat the oven when using this setting when cooking from frozen.

Note:

When the  functions have been selected but the temperature knob is set to zero only the fan will be on. With this function you can cool the dish or the oven chamber.

Note:

When selecting any heating function (switching a heater on etc.) the oven will only be switched on after the temperature has been set by the temperature regulator knob.

OPERATION

Fast oven heat-up

In ovens with the function Fan & Combined Grill, pre-heating up to 150 deg C may be up to 50% quicker using this function.

Mode of operation:

! Set the oven function to Fan & Combined Grill.

! set the temperature regulator knob to the position of 150°C .

! the oven warms up to the temperature of 150°C (or lower if set) ; the oven reaching the temperature is signalled by the red light of the temperature regulator switching off.

! insert prepared ingredients into oven .

! adjust function to desired if different from Fan & Combined Grill.

Important!

When the fast oven heat-up function has been selected, the chamber should not contain a baking tray with dough or other elements that do not constitute the oven fittings.

CLEANING AND MAINTENANCE

By ensuring proper cleaning and maintenance of your cooker you can have a significant influence on the continuing fault-free operation of your appliance.

Before you start cleaning ,the cooker must be switched off and you should ensure that all knobs are set to the “●”/”0”position. Do not start cleaning until the cooker has completely cooled.

Caution ! The sharp blade should always be protected by adjusting the cover (just push it with your thumb).Injuries are possible so be careful when using this instrument-keep out of reach of reach of children

! Bio-degradable or natural cleaning products are recommended e.g. baking soda, lemon, vinegar etc.
Otherwise, specialised oven cleaners may also be used.

CLEANING AND MAINTENANCE

Oven

! The oven should be cleaned after every use. When cleaning the oven the lighting may be switched on to enable you to see the surfaces better.

! The oven chamber should only be washed with warm water and a small amount of bio-degradable washing up solution. Alternatively, mix baking soda with water for a quick fix.

! After cleaning the oven chamber wipe it dry.

Caution!

Do not use cleaning products containing abrasive materials for the cleaning and maintenance of the glass front panel or the oven chamber to prevent damage to these surfaces.

! Steam Cleaning

-pour 250ml of water(1 glass)into a bowl placed in the oven on the first level from the bottom,

-close the oven door,

-set the temperature knob to 50°C ,and the function knob to the bottom heater position,

-heat the oven chamber for approximately 30 minutes,

-open the oven door, wipe the chamber inside with a cloth or sponge and wash using warm water with washing-up liquid.

Caution! Possible moisture or water residues under the cooker can result from steam cleaning.

! After cleaning the oven chamber wipe it dry.

Replacement of the oven light bulb

In order to avoid the possibility of an electric shock ensure that the appliance is switched off before replacing the bulb.

! Set all control knobs to the position "●"/"0" and disconnect the mains plug,

! unscrew and wash the lamp cover and then wipe it dry.

! unscrew the light bulb from the socket, replace the bulb with a new one-a high temperature bulb (300°C)with the following parameters:

-voltage 230 V

-power 25 W

-G9

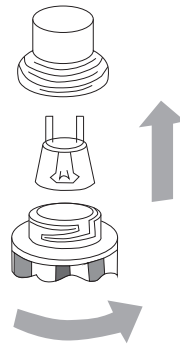

Oven light bulb

! Screw the bulb in , making sure it is properly inserted into the ceramic socket.

! Screw in the lamp cover.

CLEANING AND MAINTENANCE

▶ Removing the doors

- a. The oven door is fully open.

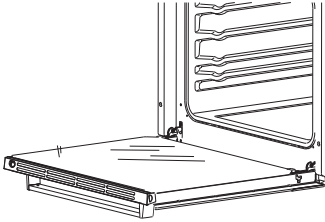

- b. The latch hinges completely lifted.

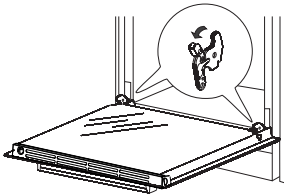

- c. Gently close the oven door until you hear the sound of engagement, once they reach a clamping position, with both hands holding the door and continue to push, pull up at the same time so that the hinge bolt removed from the oven

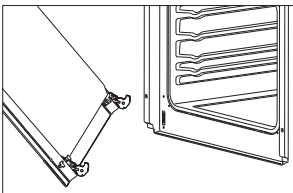
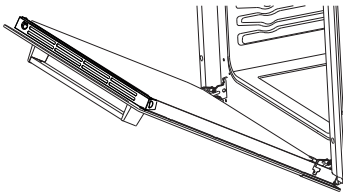

- d. After cleaning, align the hinge with the oven door. Latch and push it until it catches. Take care to ensure that the hinge and door are properly

aligned to avoid door damage.

If in doubt, contact the service centre - information is listed on the back of this user manual.

- e. With the oven door fully opened, push the latch down to its initial position to complete the oven door installation.

▶ Remove the inner glass panel

- a. Press and hold the two sides of the grid with both hands to pull it out .

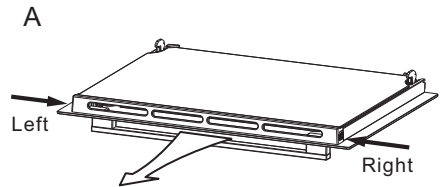

Pull out the grid

- b. Remove the inner glass .

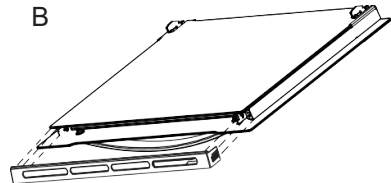

- c. Locate the glass stopper and remove it. Remove the glass for cleaning. To reinstall the inner glass, simply gently place it back onto the door and reinsert the glass stopper to secure the glass in place.

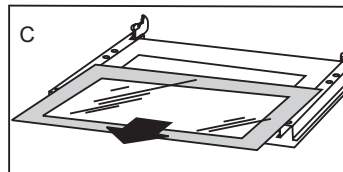

OPERATION IN CASE OF EMERGENCY

In the event of an emergency, you should:

- ! switch off all working units of the cooker
- ! disconnect the mains plug
- ! call the service centre

PROBLEM	REASON	ACTION
The appliance does not work.	break in power supply	check the household fuse box, if there is a blown fuse replace it with a new one
The oven lighting does not work	the bulb is loose or damaged	tighten up or replace the blown bulb (see chapter Cleaning and Maintenance)
The appliance causes tripping during heating. *Applicable to appliances that have not been used for long periods of time.	Moisture buildup on internal wires	Heat the oven gradually, from the lowest available temperature to the highest available temperature with temperature increments being 10deg C at a time. Allow the oven to remain at each set temperature for approximately 10mins before further increasing the temperature.

BAKING IN THE OVEN - PRACTICAL HINTS

Baking

- Use baking trays provided with the appliance.
- When selecting cake tins or trays, black or dark coloured tins often conduct heat better and shorten baking time. Bright and shiny surfaces require longer heating time to prevent undercooking.
- Before cake is removed from the oven, check if it is ready using a wooden tooth pick or stick (there should not be any moist residue on the stick if cake is ready).
- For cake, allow it some time to cool and rest after cooking. Premature removal and serving will cause most cakes to collapse.
- Let cookie dough rest in the refrigerator for at least a day before baking.
- If using the oven for baking at higher altitudes (1km above sea level) adjust baking time and temperature and ingredients -- Increase the oven temperature by 10 Deg C, liquid by 2 tablespoons for each cup used. Decrease each cup of sugar by 1 tablespoon, each teaspoon of baking powder by $\frac{1}{8}$ teaspoon, and the baking time by 5 minutes.
- The baking parameters in this user manual are approximate and can be corrected based on your own experiences and cooking preferences.

BAKING IN THE OVEN - PRACTICAL HINTS

The following menus are for reference only:

TABLE 1:Cakes

Oven functions: **bottom + top heaters**

ultra-fan

CAKE TYPE	BOTTOM-TOP HEATERS		ULTRA-FAN		BAKING TIME [min]
	LEVEL	TEMPERATURE [°C]	LEVEL	TEMPERATURE [°C]	
Baking in cake tins					
Sponge cake/marble cake	2	170-180	2	150-170	60-80
Victoria sponge	2	160-180	2	150-170	68-80
Base for a layer cake	2-3	170-180	2-3	160-170	20-30
Sponge layer cake	2	170-180			30-40
Fruit cake (crispy base)			2-3	160-180	60-70
Cheesecake (shortcrust base)			2	140-150	60-90
Teacake	2	160-180	2	150-170	40-60
Bread (e.g. wholegrain bread)	2	210-220	2	180-200	50-60
Baking on the trays prays provided with the cooker					
Fruit cake (crispy base)	3	170-180	2	160-170	35-60
Fruit cake (with yeast)			2	160-170	30-50
Crumble cake	3	160-170	2	150-170	30-40
Sponge roll	2	180-200			10-15
Pizza (thin base)	3	200-240			10-15
Pizza (thick base)	2	190-210			30-50
Baking smaller items					
Buns	3	160-170	2	150-160	10-30
Puff pastry	3	180-190	2	170-190	18-25
Meringues	3	90-110			80-90
Choux buns			2	170-190	35-45

BAKING IN THE OVEN - PRACTICAL HINTS

TABLE 1A: Cakes

Oven functions: cake (bottom and top heaters + fan)

BAKING TYPE	TEMPERATURE [°C]	BAKING TIME [min]
Baking in cake tins		
Meringues	80	60-70
Victoria sponge	150	65-70
Teacake	150	60-70
Layer cake	150	25-35
Baking on the trays provided with the cooker		
Yeast cake	150	40-45
Crumble cake	150	30-45
Fruit cake	150	40-55
Sponge cake	150	30-40

Caution!

Preheat the oven before baking.
Using the third level from the bottom is recommended.

Roasting meat

- ! cook meat weighing over 1 kg in the oven, but smaller pieces should be cooked on the gas burners.
- ! use heatproof ovenware for roasting with handles that is resistant to high temperatures;
- ! when roasting on the drying rack or the grate we recommend that you place a baking tray with a small amount of water on the lowest level of the oven;
- ! It is advisable to turn meat over at least once during the roasting time and during roasting you should also baste the meat with its juices or with hot salty water-do not pour cold water over the meat.

BAKING IN THE OVEN - PRACTICAL HINTS

TABLE 2: Roasting meat

Oven functions: **bottom and top heaters**

Ultra - fan

TYPE OF MEAT	LEVEL FROM THE BOTTOM		TEMPERATURE[°C]		TIME °C IN MINUTES
	ULTRA-FAN	BOTTOM+ TOP HEATERS	ULTRA-FAN	BOTTOM+ TOP HEATERS	
BEEF Roast beef or fillet rare oven warmed up Juicy("medium") oven warmed up "well done" oven warmed up Roast joint		3		250	12-15
		3		250	15-25
		3		210-230	25-30
	2	2	160-180	200-220	120-140
PORK Roast joint Ham Fillet		2		200-210	90-140
	2	2	160-180	200-210	60-90
		3		210-230	25-30
VEAL	2	2	160-170	200-210	90-120
LAMB	2	2	160-180	200-220	100-120
VENISON	2	2	175-180	200-220	100-120
POULTRY Chicken Goose(approx.2 kg)	2	2	170-180	220-250	50-80
	2	2	160-180	190-200	150-180
FISH	2	2	175-180	210-220	40-55

- **the figures presented in the table refer to a portion of 1 kg** ,if the portion is larger than that an additional 30-40 minutes should be added for each additional kilogram.

Caution!

In the middle of the roasting time the meat must be turned over.
It is advisable to roast meat in heatproof overware.

BAKING IN THE OVEN - PRACTICAL HINTS

TABLE 4: Fan with grill

Oven functions: combined grill + fan
 grill + fan

TYOE OF MEAT	WEIGHT [kg]	LEVEL FROM THE BOTTOM	TEMPERATURE [°C]	BAKING [MINUTES]
Roast pork	1.0	2	170-190	80-100
	1.5	2	170-190	100-120
	2.0	2	170-190	120-140
Leg of lamb	2.0	2	170-190	90-110
Roast beef	1.0	2	180-200	30-40
Chicken	1.0	2	180-200	50-60
Duck	2.0	1-2	170-190	85-90
Goose	3.0	2	140-160	110-130
Turkey	2.0	2	180-200	110-130
	3.0	1-2	160-180	150-180

During baking you should turn the meat over periodically as well as basting it with its juices or with hot salty water.

Caution!

The figures given in the Tables are approximate and can be adapted based on your own experience and cooking preferences.

TECHINCAL DATA

Voltage rating	220-240V~ 50/60 Hz
Power rating	max. 2.9kw
Cooker dimensions H/W/D	59. 5/59. 5/53.0
Usable capacity of the oven *	75 liters
Weight	Approx. 31.5kg

Our after sales team is here for you if you require any appliance assistance.

When contacting us, please provide the product number and product serial number so we are able to provide you with the correct advice and assistance. The rating plate with these numbers can be found inside the appliance

Please note that a visit by an after-sales provider may chargeable if a product turns out to be a result of operator or installer error even during warranty period.

Warranty & customer service



e-Warranty Registration at
<https://mayercare.biz/eWarranty>
Customer Service Hotline: 6542-8383
[Mon, Wed & Fri: 9:00am to 6:00pm]
[Tue & Thurs: 9:00am to 8:00pm]
[Sat: 9:00am to 3pm]
Closed: Sunday & Public Holidays
71 Ubi Crescent, #06-02, Excalibur Centre, Singapore 408571

Download Mayer App via

