



mayer



Built-In Combi Steam Oven MMSO17-RG

- Energy class: A+
- Temperature range between 30°C-250°C
- 5 hours timer
- Triple glazed glass door
- Enamel cavity wall
- Digital display + slider controls
- 15 Cooking functions, including pure steaming
- 32 Automatic menu
- 1.2L Removable water tank with 1 hour duration usage
- Delay start function
- Cavity cooling system
- Descaling & self-drying function
- Removable door plate
- 5 Shelf positions
- Quick preheat
- Child lock
- Accessories:
 - Deep baking tray x1
 - Grilling rack x1
 - Steaming tray x1
 - Meat probe x1

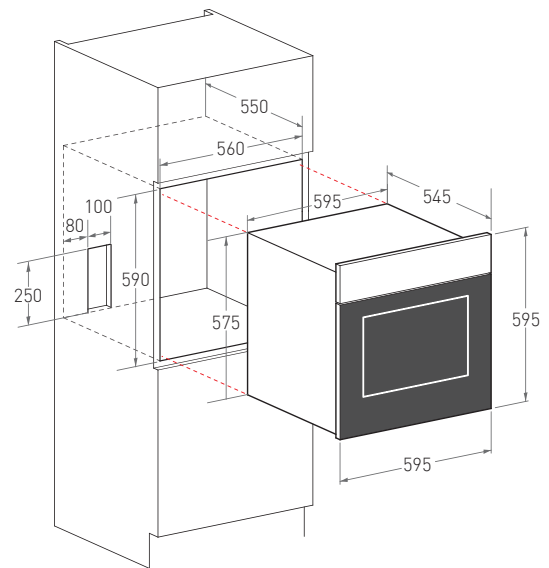

Model	MMSO17-RG
Gross Capacity	72L
Voltage	220-240V~, 50Hz-60Hz
Wattage	3.15kW / 13 AMP
Electrical Cord Length	100 cm
Plug Type	No Plug

Product Dimension	L595*W545*H595 mm
Built-In Dimension	L560*W550*H590 mm
Net Weight	39 KGS
Gross Weight	45 KGS



e-Warranty registration
www.mayer.sg











Built-In Combi Steam Oven

MMSO17-RG





mayer

Functions

Bake Function

Icons	Types of Heating	Temperature	Description
	Conventional	30 - 250°C	For traditional baking and roasting on one level. Especially suitable for cakes with moist toppings.
	Convection	50 - 250°C	For baking and roasting on one or more levels. Heat comes from the ring heater surrounding the fan evenly.
	Double Grill + Fan	50 - 250°C	For grilling flat items and for browning food. The fan distributes the heat evenly around the cavity.
	Conventional + Fan	50 - 250°C	For baking and roasting on one or more levels. The fan distributes heat from the heating elements evenly around the cavity.
	Radiant Heat	150 - 250°C	For grilling small amounts of food and for browning food. Please put the food in the center part under the grill heating element.
	Bottom Heat	30 - 200°C	For add extra browning to the bases of pizzas, pies, and pastries. Heating come from the bottom heater.
	Dough Proving	30 - 45°C	For making yeast dough and sourdough to prove and culturing yogurt.
	Drying function	-	It is used to dry the furnace chamber and prevent bacteria from growing
	ECO	140 - 240°C	For energy-saved cooking.

Steam Bake Function

Icons	Types of Heating	Temperature	Description
	Conventional + Steam	160 - 230°C	For traditional baking and roasting on one level. Especially suitable for cakes with moist toppings.
	Convection + Steam	160 - 250°C	For baking and roasting on one or more levels. Heat comes from the ring heater surrounding the fan evenly.
	Conventional + Fan + Steam	160 - 230°C	For baking and roasting on one or more levels. The fan distributes heat from the heating elements evenly around the cavity.
	Radiant Heat + Steam	160 - 235°C	For grilling small amounts of food and for browning food. Please put the food in the center part under the grill heating element.
	Bottom Heat + Steam	160 - 200°C	For add extra browning to the bases of pizzas, pies, and pastries. Heating come from the bottom heater.

Pure Steam

Icons	Types of Heating	Temperature	Description
	Pure Steam	100°C	Use for steaming food such as mantou, steamed eggs, rice, soup, steamed vegetables, steamed seafood, etc.