

Mayer Built in Oven Instruction

MODEL :MMSO17-RG

SAVE THESE INSTRUCTIONS CAREFULLY

Please read this instruction guide carefully before using the oven to familiarise yourself quickly with its operation. Keep it for future usage.

CONTENTS

4 SAFETY INFOR

- 4 Intended use
 - 4 Warning
 - 6 Causes of damage
-

7 INSTALLATION

- 8 Component
 - 9 Before using the appliance
 - 10 Function is introduced
 - 14 Using your appliance
-

17 ACCESSORIES

19 ENERGY EFFICIENT USE

20 ENVIRONMENT

20 HEALTH

20 MAINTENANCE YOUR APPLIANCE

23 APPLIANCE DOOR

28 CURE YOUR APPLIANCE WHEN NEEDED

30 CUSTOMER SERVICE

31 TIPS AND TRICKS

33 ENERGY EFFICIENCY ACCORDING TO EN 60350-1

34 COOKING BY ECO MODE

34 DATASHEET (EU 65/2014 & EU 66/2014)

SAFETY INFORMATION

Intended Use

Thank you for buying Mayer Built-in Oven. Before unpacking it, please read these instructions carefully. Only then will you be able to operate your appliance safely and correctly. Warmly recommend retain the instruction manual and installation instructions for future use or for subsequent owners.

The appliance incorporates an earth connection for functional purposes only.

The appliance is only intended to be fitted in a kitchen. Observe the special installation instructions.

Check the appliance if there is any damage after unpacking it. Do not connect the appliance if it has been damaged. Only a licensed professional may connect appliances without plugs. Damage caused by incorrect connection is not covered under warranty. Only use this appliance indoors. The appliance must only be used for the preparation of food and drink. The appliance must be supervised during operation.

This appliance may be used by children over the age of 8 and by persons with reduced physical, sensory or mental capabilities or by persons with a lack of experience or knowledge if they are supervised or are instructed by a person responsible for their safety how to use the appliance safely and have understood the associated hazards.

Children must not play with, on, or around the appliance. Children must not clean the appliance or carry out general maintenance unless they are at least 8 years old and are being supervised.

Keep children below the age of 8 years old at a safe distance from the appliance and power cable.

And please always slide accessories into the cavity the right way round.

WARNING

Risk of electric shock!

1. Incorrect repairs are dangerous. Repairs may only be carried out and damaged power cables replaced by one of our trained after-sales technicians. If the appliance is defective, unplug the appliance from the mains or switch off the circuit breaker in the fuse box. Contact the aftersales service.
2. The cable insulation on electrical appliances may melt when touching hot parts of the appliance. Never bring electrical appliance cables into contact with hot parts of the appliance.
3. Do not use any high-pressure cleaners or steam cleaners, which can result in an electric shock.
4. A defective appliance may cause electric shock. Never switch on a defective appliance. Unplug the appliance from the mains or switch off the circuit breaker in the fuse box. Contact the after-sales service.

Risk of burns!

1. The appliance becomes very hot. Never touch the interior surfaces of the appliance or the heating elements.
2. Always allow the appliance to cool down.
3. Keep children at a safe distance.
4. Accessories and ovenware become very hot. Always use oven gloves to remove accessories or ovenware from the cavity.
5. Alcoholic vapors may catch fire in the hot cooking compartment. Never prepare food containing large quantities of drinks with high alcohol content. Only use small quantities of drinks with high alcohol content. Open the appliance door with care.

Risk of scalding!

1. The accessible parts become hot during operation. Never touch the hot parts. Keep children at a safe distance.
2. When you open the appliance door, hot steam can escape. Steam may not be visible, depending on its temperature. When opening, do not stand too close to the appliance. Open the appliance door carefully. Keep children away.
3. Water in a hot cavity may create hot steam. Never pour water into the hot cavity.

Risk of injury!

1. Scratched glass in the appliance door may develop into a crack. Do not use a glass scraper, sharp or abrasive cleaning aids or detergents.
2. The hinges on the appliance door move when opening and closing the door, and you may be trapped. Keep your hands away from the hinges.

Risk of fire!

1. Combustible items stored in the cavity may catch fire. Never store combustible items in the cavity. Never open the appliance door if there is smoke inside. Switch off the appliance and unplug it from the mains or switch off the circuit breaker in the fuse box.
2. A draught is created when the appliance door is opened. Greaseproof paper may come into contact with the heating element and catch fire. Do not place greaseproof paper loosely over accessories during preheating. Always weight down the greaseproof paper with a dish or a baking tin. Only cover the surface required with greaseproof paper. Greaseproof paper must not protrude over the accessories.

Hazard due to magnetism!

Permanent magnets are used in the control panel or in the control elements. They may affect electronic implants, e.g. heart pacemakers or insulin pumps. Wearers of electronic implants must stay at least 10 cm away from the control panel.

Causes of Damage

1. Accessories, foil, greaseproof paper or ovenware on the cavity floor: do not place accessories on the cavity floor. Do not cover the cavity floor with any sort of foil or greaseproof paper. Do not place ovenware on the cavity floor if a temperature of over 50 °C has been set. This will cause heat to accumulate. The enamel will be damaged.
2. Aluminum foil: Aluminum foil in the cavity must not come into contact with the door glass. This could cause permanent discoloration of the door glass.
3. Silicone pans: Do not use any silicone pans, or any mats, covers or accessories that contain silicone. The oven sensor may be damaged.
4. Water in a hot cooking compartment: do not pour water into the cavity when it is hot. This will cause steam. The temperature change can cause damage to the enamel.
5. Moisture in the cavity: Over an extended period of time, moisture in the cavity may lead to corrosion. Allow the appliance to dry after use. Do not keep moist food in the closed cavity for extended periods of time. Do not store food in the cavity.
6. Cooling with the appliance door open: Following operation at high temperatures, only allow the appliance to cool down with the door closed. Do not trap anything in the appliance door. Even if the door is only left open a crack, the front of nearby furniture may become damaged over time. Only leave the appliance to dry with the door open if a lot of moisture was produced while the oven was operating.
7. Fruit juice: when baking particularly juicy fruit pies, do not pack the baking tray too generously. Fruit juice dripping from the baking tray leaves stains that cannot be removed. If possible, use the deeper universal pan.
8. Extremely dirty seal: If the seal is very dirty, the appliance door will no longer close properly during operation. The fronts of adjacent units could be damaged. Always keep the seal clean.
9. Appliance door as a seat, shelf or worktop: Do not sit on the appliance door or place or hang anything on it. Do not place any cookware or accessories on the appliance door.
10. Inserting accessories: depending on the appliance model, accessories can scratch the door panel when closing the appliance door. Always insert the accessories into the cavity as far as they will go.
11. Carrying the appliance: do not carry or hold the appliance by the door handle. The door handle cannot support the weight of the appliance and could break.
12. If you use the residual heat of the switched off oven to keep food warm, a high moisture content inside the cavity can occur. This may lead to condensation and can cause corrosion damage of your high quality appliance as well as harm your kitchen. Avoid condensation by opening the door or use "Defrost" mode.

INSTALLATION

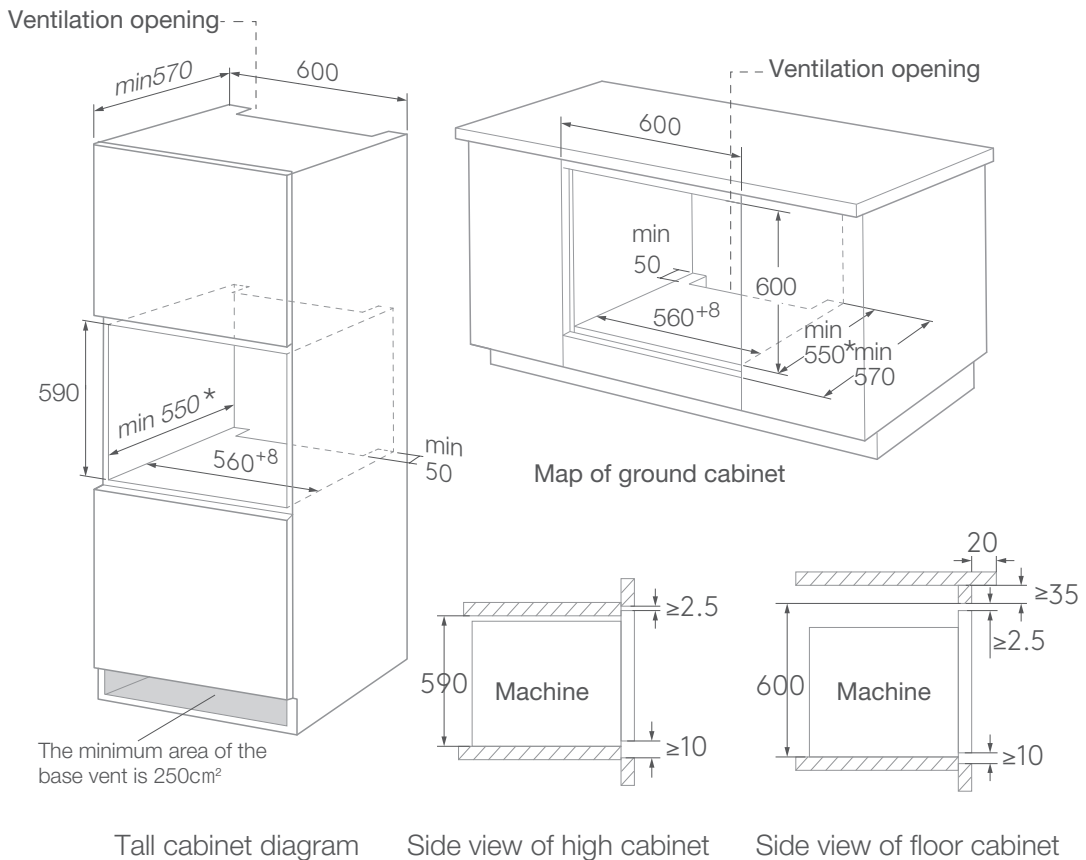

To operate this appliance safe , please be sure that it has been installed to a professional standard respecting the installation instructions . Damages occur because of incorrect installation are not within the warranty.

While doing the installation , please wear protective gloves to prevent yourself from getting cut by sharp edges .

Check the appliance if there is any damage before installation and do not connect the appliance if there is .

Before turning on the appliance , please clean up all the packaging materials and adhesive film from the appliance









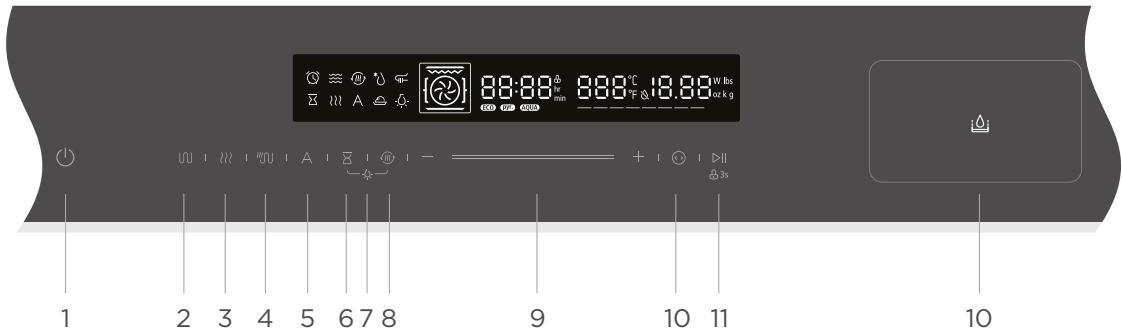





The dimensions attached are in mm.

It is necessary to have the plug accessible or incorporate a switch in the fixed wiring, in order to disconnect the appliance from the supply after installation when necessary.

Warning: The appliance must not be installed behind a decorative door in order to avoid overheating.

COMPONENT



	1. ON / OFF	Switch on and off oven.
	2. Bake	Click, select bake function.
	3. Pure steam	Click, select pure steam function.
	4. Steam bake	Click, select the steam bake function.
	5. Automatic menu	Select the Auto menu.
	6. Delay start function	Set the cooking end time.
	7. Lamp	Press  key and  key at the same time, to switch on and off the oven light lamp.
	8. Quick preheat	Use this to have a quick preheat.
	9. Slider	Slide to adjust cooking temperature and time.
	10. Temperature/time/steam adjustment	Set the cooking temperature/time/steam.
	11. Start/stop/child lock	Short press to start/pause the cooking process. Press for 3 seconds for child lock.
	10. Water tank	Water tank for steam function. Press the water tank and fill up with water.

BEFORE USING THE APPLIANCE

First using for the first time

Before using the appliance to prepare food for the first time, you must clean the cavity and accessories.

1. Remove all stickers, surface protection foils and transport protection parts.
2. Remove all accessories and the side-racks from the cavity.
3. Clean the accessories and the side-racks thoroughly using soapy water and a dish cloth or soft brush.
4. Ensure that the cavity does not contain any leftover packaging, such as polystyrene pellets or wooden piece which may cause risk of fire
5. Wipe the smooth surfaces in the cavity and the door with a soft, wet cloth.
6. To remove the new-appliance smell, heat up the appliance when empty and with the oven door closed.
7. Keep the kitchen highly ventilated while the appliance is heating up first time. Keep children and pets out of the kitchen during this time. Close the door to the adjacent rooms.
8. Adjust the settings indicated. You can find out how to set the heating type and the temperature in the next section.

Settings





Heating Mode	
Temperature	250°C
Time	1h

After the appliance has cooled down:

1. Clean the smooth surfaces and the door with soapy water and a dish cloth.
2. Dry all surfaces
3. Install the side-racks

Setting the time

Before the oven can be used, the time should be set.

1. Initially power on, the hour bit "00" flashes, and the hour bit of the clock is adjusted by " " or +/- key.
2. Press " " to confirm, the minute position "00" flashes, adjust the clock minute position by " " or +/-, and press " " to complete the setting.

NOTE:

1. If you need to modify the clock again, please hold the " " key for 3 seconds and refer to steps 1 and 2 to complete the modification.
2. The clock has a 24 hour display.

FUNCTION IS INTRODUCED

Your device has multiple modes of operation to make your device easier to use. To help you find the right way to heat them, we explain the differences and the range of applications here.

Bake function





General operation: select grill function, adjust time or temperature, start cooking.

Types of Heating		Temperature	Use
	Conventional	30~250℃	For traditional baking and roasting on one level. Especially suitable for cakes with moist toppings.
	Convection	50~250℃	For baking and roasting on one or more levels. Heat comes from the ring heater surrounding the fan evenly.
	Double Grill + Fan	50~250℃	For grilling flat items and for browning food. The fan distributes the heat evenly around the cavity.
	Conventional + Fan	50~250℃	For baking and roasting on one or more levels. The fan distributes the heat from the heating elements evenly around the cavity.
	Radiant Heat	150~250℃	For grilling small amounts of food and for browning food. Please put the food in the center part under the grill heating element.
	Bottom Heat	30~200℃	For add extra browning to the bases of pizzas, pies, and pastries. Heating come from the bottom heater.
	Dough Proving	30~45℃	For making yeast dough and sourdough to prove and culturing yogurt.
	Drying function	–	It is used to dry the furnace chamber and prevent bacteria from growing
	ECO	140~240℃	For energy-saved cooking.

Steam bake function

General operation: select the steaming function, adjust the cooking time/temperature/steam amount, and start cooking.

The steam grill function, can make the food softer, the skin is more crispy!

Types of Heating	Temperature	Use
 Conventional+steam	160-230°C	For traditional baking and roasting on one level. Especially suitable for cakes with moist toppings.
 Convection+steam	160 -250°C	For baking and roasting on one or more levels. Heat comes from the ring heater surrounding the fan evenly.
 Conventional + Fan +steam	160-230°C	For baking and roasting on one or more levels. The fan distributes the heat from the heating elements evenly around the cavity.
 Bottom Heat+steam	160-200°C	For add extra browning to the bases of pizzas, pies, and pastries. Heating come from the bottom heater.
 Radiant Heat+steam	160-235°C	For grilling small amounts of food and for browning food. Please put the food in the center part under the grill heating element.

Note

1. Before using the steam baking function, please add pure water to the tank.
2. The steam is L1-L3, and the amount of steam is increasin
3. When the steam grill function is activated, in addition to the barbecue icon will displayed, steam icon  will also be displayed.

Caution!

If you open the appliance door during an on-going operation, the operation will be paused. Please be especially careful with the risk of burns.











Cooling fan

The cooling fan switches on and off as required. The hot air escapes above the door.

Automatic menu

General operation: Select automatic menu function, select menu, start cooking.

Pure steam menu











Display	Menu	Function or Temperature	Cooking time	Preheating
01	Mantou	 100°C	25 min	NO
02	Baby Chinese Cabbage	 100°C	18 min	NO
03	Garlic Eggplant	 100°C	20 min	NO
04	Steam egg	 100°C	22 min	NO
05	Shrimp Steamed Egg Soup	 100°C	13 min	NO
06	Bacon Glutinous Rice	 100°C	40 min	NO
07	Tang Hoon Scallop	 100°C	10 min	NO
08	Garlic Prawn	 100°C	10 min	NO
09	Beef	 100°C	25 min	NO
10	Ginseng Chicken Soup	 100°C	2 H	NO
11	Pork Ribs and Lotus Root Soup	 100°C	2 H	NO
12	Osmanthus Yam Cake	 100°C	25 min	NO
13	Steamed Sea Bass	 100°C	15 min	NO
14	Salmon Fillet	 100°C	15 min	NO
15	Grains	 100°C	40 min	NO

Caution!



















Do not cover the ventilation slots. Otherwise, the appliance may overheat.

To make the appliance cool down more quickly after the operation, the cooling fan may continue to run for a period afterwards.

Bake menu



Display	Menu	Function or Temperature	Cooking time	Preheating
16	Baked Pasta	 220°C	10 min	Yes
17	Roast Beef	 250°C	8 min	Yes
18	Chiffon Cake	 150°C	50 min	Yes
19	Shepherd's pie	 100°C	30 min	NO
		 200°C	20 min	Yes
20	Crispy pork belly	 180°C	45 min	Yes
		 230°C	18 min	NO
		 210°C	4 min	NO
21	Fruit Pie	 190°C	22 min	Yes
22	Cream Puff	 190°C	24 min	Yes
23	Pizza	 230°C	13 min	Yes

Steam bake menu

Display	Menu	Function or Temperature	Cooking time	Preheating
24	Chicken Wings	  230°C+L1	25 min	Yes
25	Pork Ribs	  200°C+L1	25 min	Yes
26	Grilled saury	  220°C+L1	14 min	Yes
27	Oven-roasted chicken with root vegetables and potatoes	  200°C+L1	55 min	Yes
28	Pork	  180°C+L1	50 min	Yes
29	Lamb Chops	  220°C+L1	25 min	Yes
30	Pork Knuckle	 230°C	60 min	NO
		 230°C+L1	20 min	NO
31	Cheese Cake	  160°C+L1	55 min	Yes
32	Chocolate Cranberry Bread	  180°C+L1	25 min	Yes

USING YOUR APPLIANCE

Cooking with oven

1. After the oven has been electrically connected, touch the oven-function symbol to select functions, use the slider or "+/-"symbol to set cooking temperature.
2. Touch  symbol, oven begin to work, if not, oven will back to clock after 5 minutes.
3. During the cooking process, you can touch  to cancel it.

NOTE: After temperature setting, you can touch clock symbol  to set the cooking duration time, you can set it by slider or "+/-"symbol.

Quick preheat

Quick preheating can be used to shorten cooking time.

Click the  symbol. The  sign on the screen will light up.

Notes

Please put the food into the oven after the preheating temperature is reached.

Change during cooking

To change the cooking time, temperature, or amount of steam in the cooking process, click the  key and use the slider or the "+/-" key to adjust.

When you want cancel the cooking process, please touch  .

Notes

Changing modes/temperature/rest cooking time may have some negative influences on the result of cooking, we warmly recommend you not to do so unless you are well experienced on cooking.

Caution!

After the appliance switched on, it becomes very hot especially inside the cavity. Never touch the interior surfaces of the appliance or the heating elements. Use oven gloves to remove accessories or ovenware from the cavity, and allow the appliance to cool down. Keep children at a safe distance at the same time to avoid the injury of burns.

Childproof lock

Your appliance has a childproof lock so that children cannot switch it on accidentally or change any settings.



Long press  for 3 seconds, the oven enters or exits the child lock function.

Power saving mode



In standby mode, after 10 minutes of non-operation, it will automatically enter the power-saving state.

In the state of power saving press any key buzzer back to standby state.

Drying function

In standby state, press Key  for 8 times to enter the drying function, adjust the drying time through slider or +/- key, and press the start key  to work.



Descaling function

1. Take out the water box, add water and half a packet of citric acid to the water box, st well, and put the water box back to the tank seat.
2. In standby mode, press The  key once and then enter the desiccating function throu the slider and press +/-, and dE5 is displayed on the screen.
3. Click The  key to start the work. When the time is counted down to "08:00 min", wat shortage is indicated.
4. Take out the tank, add water and put it back into the tank seat. Click The  key to restart work.





Notes

1. Citric acid is not delivered with the product, please buy it by yourself.

Delay start function

1. After the clock is set, press the  key to set the cooking end time.
2. Please refer to the "Clock Setup" step to set the oven time.
3. Select the function (automatic menu and preheat function do not support the delay start function. Adjust the cooking time/temperature/steam amount, and press the  key to start the work.
4. Click  key to query the appointment tim
For example, when you set end time is 10 o'clock, and cooking duration time is 1 hour, then oven will heat up at 9 o'clock, and finish at 10 o'clock.

probe function

1. In any state, insert the short end of the probe into the probe hole of the oven, "Prob" displays ; and then put the food into the oven, insert the long end of the probe into the food and close the oven door.
2. Select the grill function (  ), adjust the probe setting temperature by +/- key and click  key to start the work.
3. When the food core temperature reaches the probe set temperature, the buzzer will beep 3 times and return to the standby state.

Notes

1. While using meat probe , please make the head of it into the food instead of some-where else , for the sake of long-term using.
2. Only use the meat probe recommended for this oven.

Steam

1. When oven is under standby status, press steam key can add steam after mode is set.
2. Steam can be manually add by pressing steam key during cooking.
3. When oven is under standby status, press steam key can set steam mode and add steam for cooking. Steam level default setting as level 1.

Notes

Press "  "key, and then press "+/-"to set the steam level,"L1,L2,L3"are available.

Due to vibration caused by transportation, water box may be pop-up status after opening the package. Remember pushing it back.

Water tank

Add water

Method 1

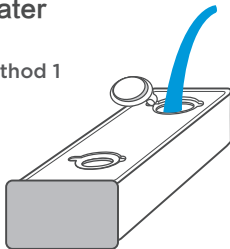

1. Press and take out the water tank. Fill with water till the maximum mark indicator on the water tank.

Method 2

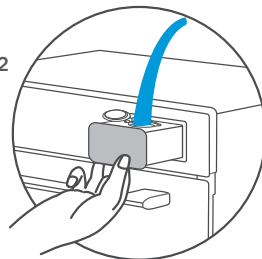

2. Press the water tank, pull out the water tank halfway and add water

Notes

When the cooking is over, please pour out the remaining water and dry the water tank.

As the product is continuously upgraded, if the picture does not match the actual product, please refer to the actual product.

ACCESSORIES

Your appliance is accompanied by a range of accessories. Here, you can find an overview of the accessories included and information on how to use them correctly.

Accessories included

Your appliance is equipped with the following accessories:

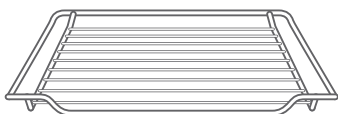

Wire Rack

For ovenware, cake tins and ovenproof dishes. For roasts and grilled food

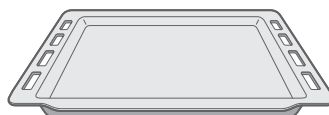

Baking Tray

For tray bakes and small baked products.

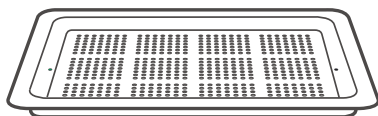

Steaming tray

Can only be used in pure steam function

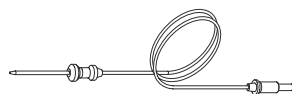

Meat probe

Insert the probe into the center of meat or poultry. Away from fat or bone

You can use the tray to place liquid or cooking food with juice.

Only use original accessories. They are specially adapted for your appliance.

You can buy accessories from the after-sales service, from specialist retailers or online.

Note

The accessories may deform when they become hot. This does not affect their function. Once they have cooled down again, they regain their original shape.

Inserting accessories

The cavity has five shelf positions. The shelf positions are counted from the bottom up. The accessories can be pulled out approximately halfway without tipping.

Notes

1. Ensure that you always insert the accessories into the cavity the right way .
2. Always insert the accessories fully into the cavity so that they do not touch the appliance door.

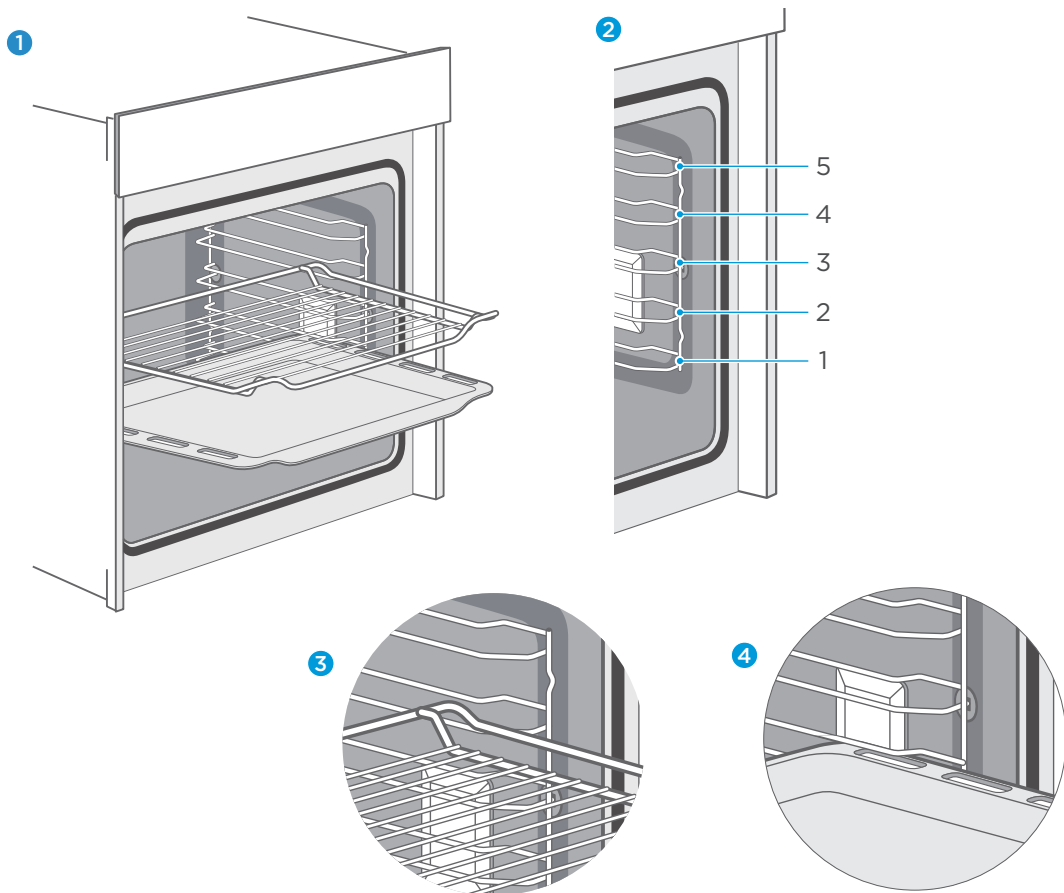

Locking function

Accessories can be approximately pulled halfway out until they lock in place. The locking function prevents accessories from tilting with the gravity of food and accessories themselves while they get pulled out. Accessories should be inserted into cavity correctly for the tilt protection. When inserting the wire rack, ensure the wire rack is onto the right facing direction like the picture **1 3**.

When inserting the backing tray, ensure the backing tray is onto the right facing direction like the picture **1 4**.

ENERGY EFFICIENT USE

1. Remove all accessories, which are not necessary during the cooking & baking process
2. Do not open the door during the cooking & baking process
3. If you open the door during cooking & baking, switch the mode to “Lamp” (Without change the temperature setting)
4. Decrease the temperature setting in not fan assisted modes to 50°C at 5min to 10min before end of cooking & baking time. So you can use the cavity heat to complete the process.
5. Use “Fan Heating”, whenever possible. You can reduce the temperature by 20°C to 30°C
6. You can cook and bake using “Fan Heating” on more than one level at the same time.
7. If it is not possible to cook and bake different dishes at the same time, you can heat one after the other to use the preheat status of the oven.
8. Do not preheat the empty oven, if it is not required.
If necessary put the food into the oven immediately after reaching the temperature indicated by switching off the indicator light the first tim
9. Do not use reflective foil, like aluminum foil to cover the cavity flo
- 10 Use the timer and or a temperature probe whenever possible
11. Use dark matt finish and light weighted baking molds and containers. Try not to use heavy accessories with shiny surfaces, like stainless steel or aluminum.

ENVIRONMENT

The packaging is made for protect your new appliance against damages during transport. The materials used are selected carefully and should be recycled. Recycling reduces the use of raw materials and waste. Electrical and electronic appliances often contain valuable materials. Please do not dispose of it with your household waste.



HEALTH

Acrylamide occurs mainly by heating up starchy food (i.e. potato, French fries, bread) to very high temperatures over long times.

Tips

1. Use short cooking times.
2. Cook food to a golden yellow surface color, do not burn it to dark brown colors.
3. Bigger portions have less acrylamide.
4. Use “Convection” mode if possible.
5. French fries: Use more than 450g per tray, place them evenly spread and turn them time by time. Use the product information if available to get the best cooking result.

MAINTENANCE YOUR APPLIANCE

Cleaning Agent

With good care and cleaning, your appliance will retain its appearance and remain fully functioning for a long time to come. We will explain here how you should correctly care for and clean your appliance.

To ensure that the different surfaces are not damaged by using the wrong cleaning agent, observe the information in the table. Depending on the appliance model, not all of the areas listed may be on/in your appliance.

Caution!

Risk of surface damage

Do not use:

1. Harsh or abrasive cleaning agents.
2. Cleaning agents with a high alcohol content.
3. Hard scouring pads or cleaning sponges.
4. High-pressure cleaners or steam cleaners.
5. Special cleaners for cleaning the appliance while it is hot.

Wash new sponge cloths thoroughly before use.

Tip

Highly recommended cleaning and care products can be purchased through the after-sales service.

Observe the respective manufacturer's instructions.

Area Appliance exterior	Cleaning
Appliance exterior Stainless steel front	Hot soapy water: Clean with a dish cloth and then dry with a soft cloth. Remove flecks of limescale, grease, starch and albumin (e.g. egg white) immediately. Corrosion can form under such flecks Special stainless steel cleaning products suitable for hot surfaces are available from our after-sales service or from specialist retailers. Apply a very thin layer of the cleaning product with a soft cloth.
Plastic	Hot soapy water: Clean with a dish cloth and then dry with a soft cloth. Do not use glass cleaner or a glass scraper.
Painted surfaces	Hot soapy water: Clean with a dish cloth and then dry with a soft cloth.
Control panel	Hot soapy water: Clean with a dish cloth and then dry with a soft cloth. Do not use glass cleaner or a glass scraper.
Door panels	Hot soapy water: Clean with a dish cloth and then dry with a soft cloth. Do not use a glass scraper or a stainless steel scouring pad.

Area	Appliance exterior	Cleaning
Door handle	<p>Hot soapy water: Clean with a dish cloth and then dry with a soft cloth. If descaler comes into contact with the door handle, wipe it off immediately. Otherwise, any stains will not be able to be removed.</p>	
Enamel surfaces and self-cleaning surfaces	<p>Observe the instructions for the surfaces of the cooking compartment that follow the table.</p>	
Glass cover for the interior lighting	<p>Hot soapy water: Clean with a dish cloth and then dry with a soft cloth. If the cooking compartment is heavily soiled, use oven cleaner.</p>	
Door seal Do not remove	<p>Hot soapy water: Clean with a dish cloth. Do not scour.</p>	
Stainless steel door cover	<p>Stainless steel cleaner: Observe the manufacturer's instructions. Do not use stainless steel care products. Remove the door cover for cleaning.</p>	
Accessories	<p>Hot soapy water: Soak and clean with a dish cloth or brush. If there are heavy deposits of dirt, use a stainless steel scouring pad.</p>	
Rails	<p>Hot soapy water: Soak and clean with a dish cloth or brush.</p>	
Pull-out system	<p>Hot soapy water: Clean with a dish cloth or a brush. Do not remove the lubricant while the pull-out rails are pulled out. It is best to clean them when they are pushed in. Do not clean in the dishwasher.</p>	
Meat thermometer	<p>Hot soapy water: Clean with a dish cloth or a brush. Do not clean in the dishwasher.</p>	

Notes

1. Slight differences in color on the front of the appliance are caused by the use of different materials, such as glass, plastic and metal.
2. Shadows on the door panels, which look like streaks, are caused by reflections made by the interior lighting.

3. Enamel is baked on at very high temperatures. This can cause some slight color variation. This is normal and does not affect operation. The edges of thin trays cannot be completely enameled. As a result, these edges can be rough. This does not impair the anti-corrosion protection.
4. Always keep the appliance clean and remove dirt immediately so that stubborn deposits of dirt do not build up.

Tips

1. Clean the cooking compartment after each use. This will ensure that dirt cannot be baked on.
2. Always remove flecks of lime scale, grease, starch and albumin (e.g. egg white) immediately.
3. Remove flecks of food with sugar content immediately, if possible, when the fleck is still warm.
4. Use suitable ovenware for roasting, e.g. a roasting dish.

APPLIANCE DOOR

With good care and cleaning, your appliance will retain its appearance and remain fully functional for a long time to come. This will tell you how to remove the appliance door and clean it.

For cleaning purposes and to remove the door panels, you can detach the appliance door. The appliance door hinges each have a locking lever.

When the locking levers are closed, the appliance door is secured in place. It cannot be detached. When the locking levers are open in order to detach the appliance door, the hinges are locked. They cannot snap shut.

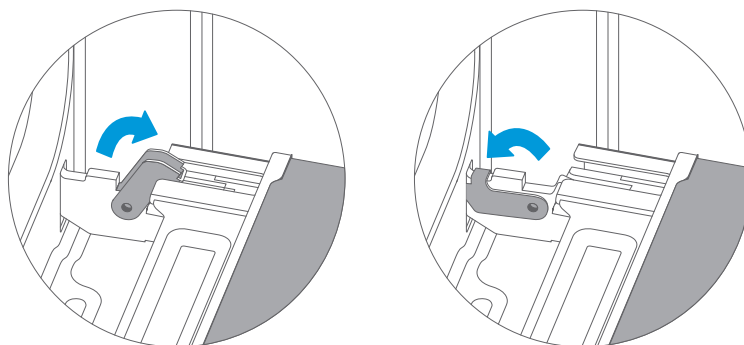

Warning – Risk of injury!

1. If the hinges are not locked, they can snap shut with great force. Ensure that the locking levers are always fully closed or, when detaching the appliance door, fully open.
2. The hinges on the appliance door move when opening and closing the door, and you may be trapped. Keep your hands away from the hinges.

Removing the appliance door

1. Open the appliance door fully.
2. Fold open the two locking levers on the left and right
3. Close the appliance door as far as the limit stop.
4. With both hands, grip the door on the left- and right-hand side, and pull it out upwards.

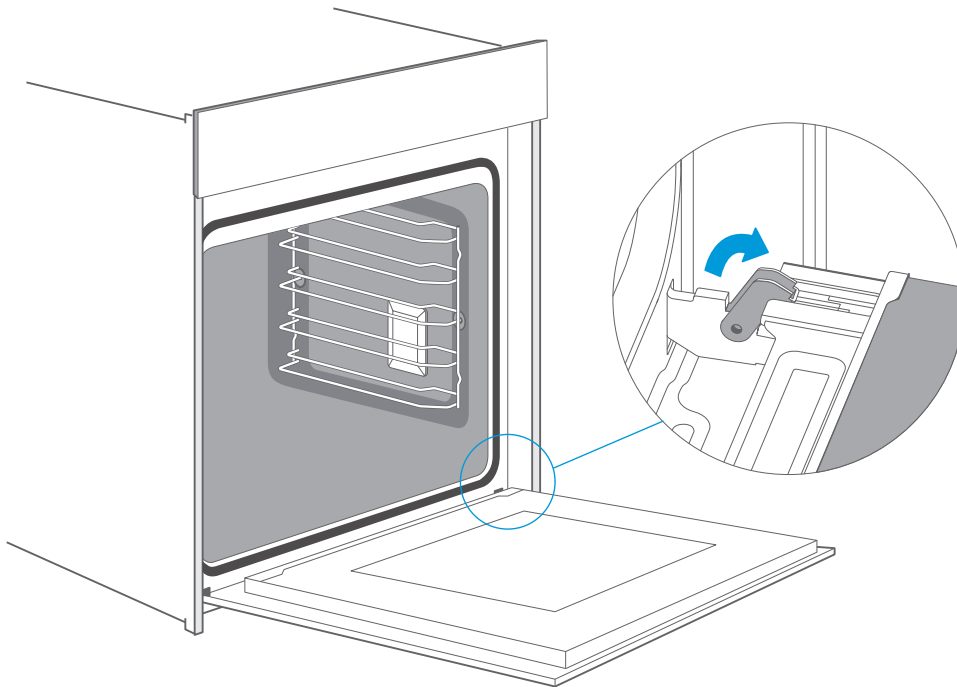

Fitting the appliance door

Reattach the appliance door in the opposite sequence to removal.

1. When attaching the appliance door, ensure that both hinges are placed right onto the installing holes of the front panel of the cavity.
Ensure that the hinges are inserted into the correct position. You must be able to insert them easily and without resistance. If you can feel any resistance, check that the hinges are inserted into the holes right.
2. Open the appliance door fully. While opening the appliance door, you can make another check if the hinges are onto the right position. If you make the fitting wrong, you will not be able to make the appliance door fully opened.
Fold both locking levers closed again.
3. Close the cooking compartment door. By the same time, we warmly recommend you to check one more time, if the door is onto the right position and if the ventilation slots are not half-sealed.

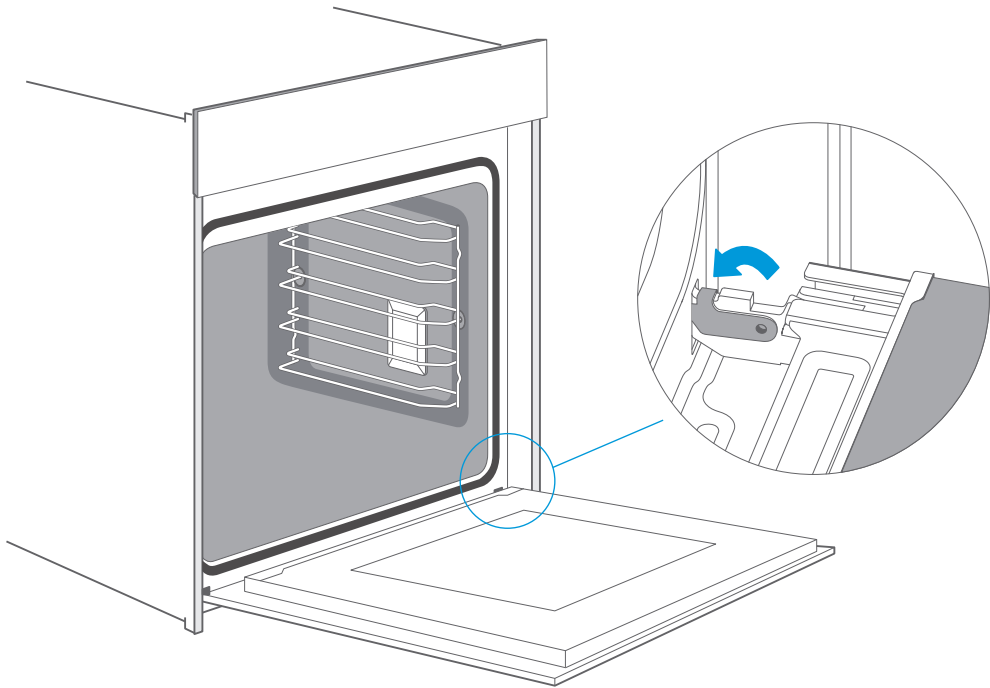

Removing the door cover

The plastic inlay in the door cover may become discolored. To carry out thorough cleaning, you can remove the cover.

[Remove the appliance door like instructed above.](#)

1. Press on the right and left side of the cover.
2. Remove the cover.
3. After removing the door cover , that rest parts of the appliance door can be easily taken off so that you can go on with the cleaning . When the cleaning of the appliance door has finis ed , put the cover back in place and press on it until it clicks audibly into place.
4. Fitting the appliance door and close it.

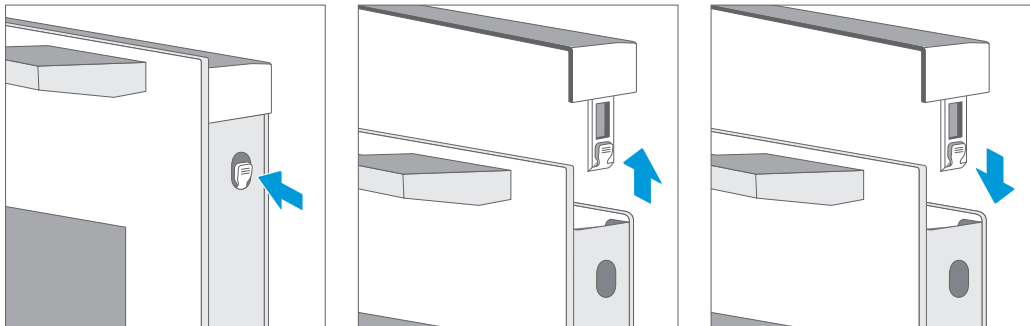

Caution!

While the appliance door is well installed, the door cover can also be taken off, by this time.

1. Removing the door cover means to set the inner glass of the appliance door free, the glass can be easily moved and cause damage or injury.
2. As removing the door cover and inner glass means to reduce the overall weight of the appliance door. The hinges can be easier to be moved when closing the door and you may be trapped. Keep your hands away from the hinges.

Because of the 2 points above, we strongly recommend you not to remove the door cover unless the appliance door removed. Damage caused by incorrect operation is not covered under warranty.

Rails

When you want have a good cleaning for the rails and cavity, you can remove the shelves and clean it. In this way your appliance will retain its appearance and remain fully functional for a long time to come.

Detaching and refitting the rails

Inserting the holders

Attaching the rails

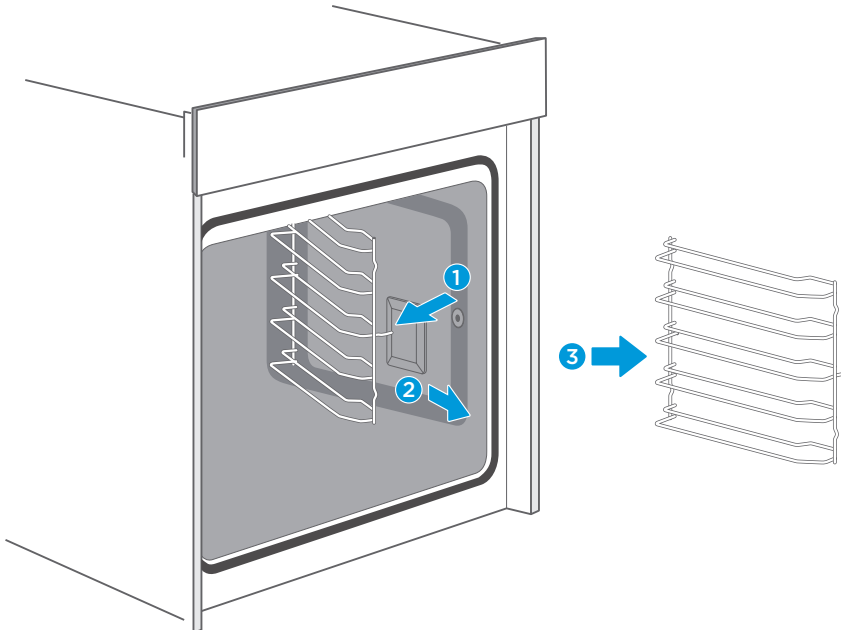

Change the power cord

Position A show the terminal box position on the back of the back outer case and it's closed.

- Steps:
- cut off the power, use small flat screwdriver to open two snap 1, 2.
 - use Phillips screwdriver to take off screws 3, 4, 5 and 6.
 - change the new power cord, fix the yellow/green wire on 3, brown wire on 4, blue wire on 5.
 - twist screw 6 closed the terminal box cover finish the changing.

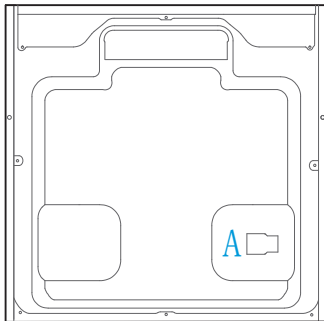

Machine back

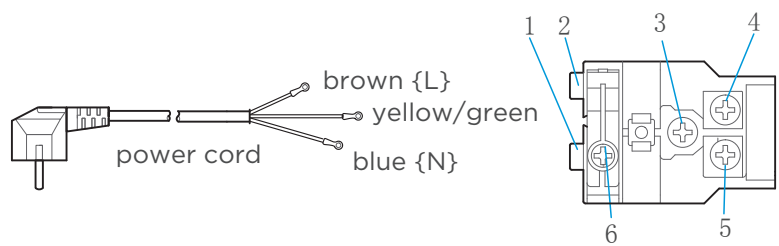

terminal box

Notes

Due to the continuous upgrading of products, there may be differences between the picture and the actual product. Please refer to the actual product received.

CURE YOUR APPLIANCE WHEN NEEDED

If a fault occurs, before calling the after-sales service, please ensure that is not because of incorrect operations and refer to the fault table, attempt to correct the fault yourself. You can often easily rectify technical faults on the appliance yourself.

If a dish does not turn out exactly as you wanted, you can find many tips and instructions for preparation at the end of the operating manual.

Fault	Possible Cause	Notes/remedy
The appliance does not work.	Faulty fuse.	Check the circuit breaker in the fuse box.
	Power cut	Check whether the kitchen light or other kitchen appliances are working.
Knobs have fallen out of the support in the control panel.	Knobs have been accidentally disengaged.	Knobs can be removed. Simply place knobs back in their support in the control panel and push them in so that they engage and can be turned as usual.
Knobs can no longer be turned easily.	There is dirt under knobs	Knobs can be removed. To disengage knobs, simply remove them from the support. Alternatively, press on the outer edge of knobs so that they tip and can be picked up easily. Carefully clean the knobs using a cloth and soapy water. Dry with a soft cloth. Do not use any sharp or abrasive materials. Do not soak or clean in the dishwasher. Do not remove knobs too often so that the support remains stable
Fan does not work all the time in the mode: "Fan Heating"		This is a normal operation due to the best possible heat distribution and best possible performance of the oven.
After a cooking process a noise can be heard and a air flow in the near of the control panel can be observed.		The cooling fan is still working, to prevent high moisture conditions in the cavity and cool down the oven for your convenience. The cooling fan will switch off automatically.

The food is not sufficient cooked in the time given by the recipe .	A temperature different from the recipe is used. Double check the temperatures. The ingredient quantities are different to the recipe. Double check the recipe.
The food is not sufficient cooked in the time given by the recipe .	A temperature different from the recipe is used. Double check the temperatures. The ingredient quantities are different to the recipe. Double check the recipe.
Uneven browning	The temperature setting is too high, or the shelf level could be optimized. Double check the recipe and settings. The surface finish and or color and or material of the baking ware were not the best choice for the selected oven function. When use radiant heat, such as "Top & Bottom Heating" mode, use matt finished, dark colored and light weighted oven ware.
The lamp doesn't turn on	The lamp needs to be replaced.

Warning-Risk of electric shock!

Incorrect repairs are dangerous. Repairs may only be carried out and damaged power cables replaced by one of our trained after-sales technicians. If the appliance is defective, unplug the appliance from the mains or switch off the circuit breaker in the fuse box. Contact the after-sales service.

Maximum operating time

The maximum operating time of this appliance is 9 hours, to prevent that you forget shot off the power.

Cooking compartment bulbs

To light the interior of your cooking compartment, your appliance has one or more long-life LED bulbs.

However, if ever an LED bulb or the bulb's glass cover is defective, call the after-sales service. The lamp cover must not be removed.

CUSTOMER SERVICE

Our after-sales service is there for you if your appliance needs to be repaired. We will always find an appropriate solution. Please contact the dealer where you buy this appliance. When calling us, please give the model number and S/N so that we can provide you with the correct advice. The rating plate bearing these numbers can be found when you open the appliance door.

Model: MMSO17-RG
Rated voltage: 220-240V~
Rated frequency: 50Hz-60Hz
Electric power: 3.15kW/ 13AMP



Warning

This appliance shall be installed in accordance with the regulations in force and only used in a well ventilated space. Read the instructions before installing or using this appliance.

Note

Please note that a visit from an after-sales service engineer is not free of charge, even during the warranty period.

Rely on the professionalism of the manufacturer. You can therefore be sure that the repair is carried out by trained service technicians who carry original spare parts for your appliances.

Above, thank you again for buying Mayer Built-in Oven, and we wish that our appliance will bring you delicious food and happy life.

TIPS AND TRICKS

You want to cook your own recipe	Try to use settings of similar recipes first and optimize the cooking process due to the result.
Is the cake baked ready?	Put a wooden stick inside the cake about 10 minutes before the given baking time is reached. If there is no raw dough at the stick after pulling out, the cake is ready.
The cake loses massive volume during cooling down after baking	Try to lower the temperature setting by 10°C and double check the food preparing instructions regarding the mechanical handling of the dough.
The height of the cake is in the middle much higher than at the outer ring	Do not grease the outer ring of the spring form
The cake is too brown at the top	Use a lower shelf level and or use a lower set temperature (this may lead to a longer cooking time)
The cake is too dry	Use a 10°C higher set temperature (this may lead to a shorter cooking time)
The food is good looking but the humidity inside is too high	Use a 10°C lower set temperature (this may lead to a longer cooking time) and double check the recipe
The browning is uneven	Use a 10°C lower set temperature (this may lead to a longer cooking time). Use the “Top & Bottom Heating” mode on one level.
The cake is less browned on the bottom	Choose a level down
Baking on more than one level at the same time: One shelf is darker than the other.	Use a fan assisted mode for baking at more than one level and take out the trays individually when ready. It is not necessary that all trays are ready at the same time.
Condensing water during baking	Steam is part of baking and cooking and moves normally out of the oven together with the cooling air flow. This steam may condensate at different surfaces at the oven or near to the oven and build water droplets. This is a physical process and cannot be avoid completely.

<p>Which kind of baking ware can be used?</p>	<p>Every heat resistant baking ware can be used. It is recommended not to use aluminum in direct contact with food, especially when it is sour. Please ensure a good fitting between container and lid.</p>
<p>How to use the grill function?</p>	<p>Preheat the oven for 5 minutes and place the food in the level given by this manual. Do not use the oven when the door is open, except for load / remove / check the food.</p>
<p>How to keep clean the oven during grilling ?</p>	<p>Use the tray filled with 2 liter of water in at level 1. Nearly all fluids drip down from the food placed on the rack will captured by the tray.</p>
<p>The heating element in all grilling modes are switching on and off over the time.</p>	<p>It is a normal operation and depends on the temperature setting.</p>
<p>How to calculate the oven settings, when the weight of a roast is not given by a recipe?</p>	<p>Choose the settings next to the roast weight and change the time slightly. Use a meat probe if possible to detect the temperature inside the meat. Place the head of the meat probe carefully in the meat, due to the manufacturer instructions. Make sure, that the head of the probe is placed in the middle of the biggest part of the meat, but not in the near of a bone or hole.</p>
<p>What happens if a fluid is poured to a food in the oven during the baking or cooking process?</p>	<p>The fluid will boil and steam will arise as a normal physical process. Please be careful, because the steam is hot. See also “Condensing water during baking” for more information. If the fluid contains alcohol, the boiling process will be quicker and can lead to flames in the cavity. Make sure, that the oven door is closed during such kind of processes. Please control the baking or cooking process carefully. Open the door very gentle and only if necessary.</p>

ENERGY EFFICIENCY ACCORDING TO EN 60350-1

Please note the following information:

1. The measurement is carried out in the “ECO” mode to determine the data regarding the forced air mode and the label-class
2. The measurement is carried out in the “Top & Bottom Heating” mode to determine the data regarding the conventional mode
3. During the measurement only the necessary accessory is in the cavity. All other parts have to be removed
4. The oven is installed as described in the installation guide and placed in the middle of the cabinet
5. It is necessary for the measurement to close the door like in the household, even when the cable disturbs the sealing function of the gasket during the measurement. To make sure, that there are no negative effects regarding the disturbed sealing due to the energy data, it is necessary to close the door carefully during the measurement. It may be required to use a tool to guarantee the sealing of the gasket like in the household, where no cable disturbs the sealing function.
6. The determination of the cavity volume carried out for the usage “Defrost” as described on page 14. To ensure an efficient use of the oven, all accessories including side-racks are removed.

COOKING BY ECO MODE

ECO mode is heat by bottom and ring heater, with this mode you can save energy during cooking.

RECIPES	Accessories	°C	Level	Time(min)	Pre-heat
Challah	1 tray	180	1	45-50	No
Pork Roast	1 tray	200	1	80-85	No
Clafouti Cherry Cake	Round form	200	1	55-60	No
Beef Roast 1.3kg	1 tray	200	1	80-85	No
Brownies	Rack and glass plate	180	1	55-60	No
Potato Gratin	Rack and round plate	180	1	65-70	No
Lasagne	Rack and glass plate	180	1	75-80	No
Cheese Cake	Springform Φ 20cm	160	1	80-90	No

DATASHEET (EU 65/2014 & EU 66/2014)

A UmYf A A GC %! F ;

No of Cavities	1
Heat Source	Electric
Usable Volume	72L
ECElectric, cavity (Conventional)	1.06kWh/cycle
ECElectric, cavity (Forced Air)	0.63kWh/cycle
EEICavity	74
Energy Efficiency Class (A+++ to D)	A+

Warranty & Customer Service

SCAN FOR



e-Warranty

e-Warranty Registration at <https://www.mayer.sg>

MAYER MARKETING PTE LTD

Customer Service Hotline: 6542-8383 (Mon - Fri 9:00am to 5:00 pm)

Service Centre Operating Hours:

Mon, Wed & Fri: 9:00am to 6:00pm

Tue & Thurs: 9:00am to 8:00pm

Sat: 9:00am to 3:00pm

Closed on Sunday & Public Holidays

71 Ubi Crescent, #06-02, Excalibur Centre, Singapore 408571.

Download Mayer App via



