

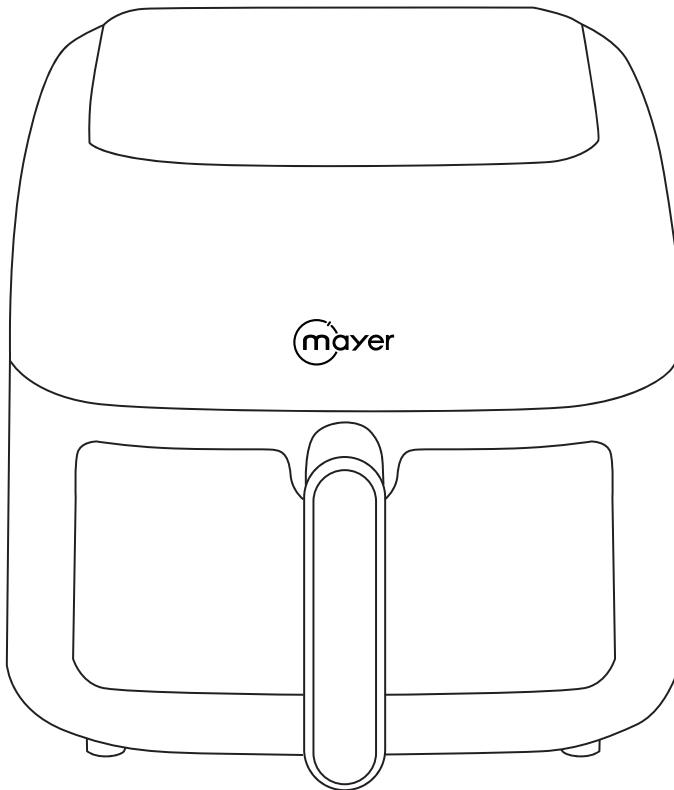



Air Fryer MMAF650D



AIR FRYER

Please read this instruction manual thoroughly before operating and keep it for future reference

IMPORTANT SAFETY INSTRUCTIONS

- This appliance is not intended for use by persons (including children) with reduced physical, sensory or mental capabilities, or lack of experience and knowledge unless they have been given supervision or instruction concerning the use of the appliance by a person responsible for their safety.
- Children should be supervised to ensure that they do not play with the appliance.
- Do not operate any appliance with a damaged cord or plug or after the appliance malfunctions, or has been dropped or damaged in any manner. If the power cord is damaged, it must be replaced by the Service Centre to avoid a hazard.
- When using electrical appliances, basic safety precautions should always be followed to reduce the risk of fire, electric shock, and/or injury.
- Unplug from the outlet when not in use and before cleaning.
- Do not unplug the appliance by pulling on the cord.
- Use the accessories from the appliance only, as other accessories not from the appliance may cause fire, electric shock or injury.
- Please remove the protective film and stickers on the air fryer before you first use.
- Do not let cord hang over edge of table or counter or touch hot surfaces.
- Do not place the appliance on or near hot gas, electric stoves, in heated ovens, or any flammable materials.
- Do not place any papers, plastics, or other flammable items into the appliance to avoid fire hazards.
- Extreme caution must be used when moving the air fryer containing hot oil or other liquids.
- Do not use appliance for other than intended purpose.
- Do not place the appliance against a wall or directly next to other appliances. Leave at least 10cm of free space around the appliance when in use.
- Do not cover the air inlet or the outlet when the appliance is operating.
- Do not fill the air fryer basket with oil as this may cause a fire hazard.
- Keep all ingredients in the frying basket, prevent any contact from heating elements.
- Avoid any liquid from entering the appliance to prevent electric shock or short-circuit.
- Do not touch the inside of the appliance when it is operating.
-  : Caution hot surface, do not touch!
- The air fryer will not operate unless the air fryer basket is fully closed.
- After cooking, the air fryer basket, the basket tray and the cooked foods are hot. Extreme caution must be used when handling the hot air fryer basket/ basket tray.
- This air fryer is for indoor and household use only; it is not suitable for outdoor, commercial and industrial use.
- To prevent fire, electric shock and injury, do not immerse wires, plugs or appliances in water or other liquids.

Note:

This appliance is equipped with a timer. When the timer has reached 0, the appliance produces a beep sound and switches off automatically.

Before the first use

- Remove all packaging materials.
- Remove any stickers or labels from the appliance. (Except the rating label)
- Thoroughly clean the frying basket and basket tray with hot water, some dishwashing liquid and a non-abrasive sponge.
- Wipe the inside and outside of the appliance with a damp cloth.
- This healthy electric oil-free air fryer works using hot air. Do not fill the fryer pot with oil or frying fats.

During use

- Use on a flat and stable, heat resistant work surface, away from any water splashes or sources of heat.
- When in operation, never leave the appliance unattended.
- This appliance is not designed to be used by people (including children) with a physical, sensory or mental impairment, or people without knowledge or experience, unless they are supervised or given prior instructions concerning the use of the appliance by someone responsible for their safety.
- Children must be supervised to ensure that they do not play with the appliance.
- This appliance operates at high temperatures which may cause burns. Do not touch the hot surfaces of the appliance (air fryer basket, air outlet).
- Do not switch on the appliance near flammable materials (blinds, curtains, etc.) or close to an external heat source (gas stove, hot plate, etc.).
- In the event of fire, never try to extinguish the flame with water if it is not dangerous to do so. Unplug the appliance and close the lid, smother the flame with a damp cloth.
- Do not move the appliance when it is full of hot food.
- Never immerse the appliance in water.

IMPORTANT: Do not fill the air fryer basket with oil or any other liquid. Do not put anything on top of the appliance.

PRODUCT TECHNICAL PARAMETERS

| MODEL | RATED VOLTAGE | RATED POWER | GROSS CAPACITY |
|----------|-------------------|-------------|----------------|
| MMAF650D | 220-240V, 50-60Hz | 1600W | 6.5L |

INTRODUCTION OF PARTS

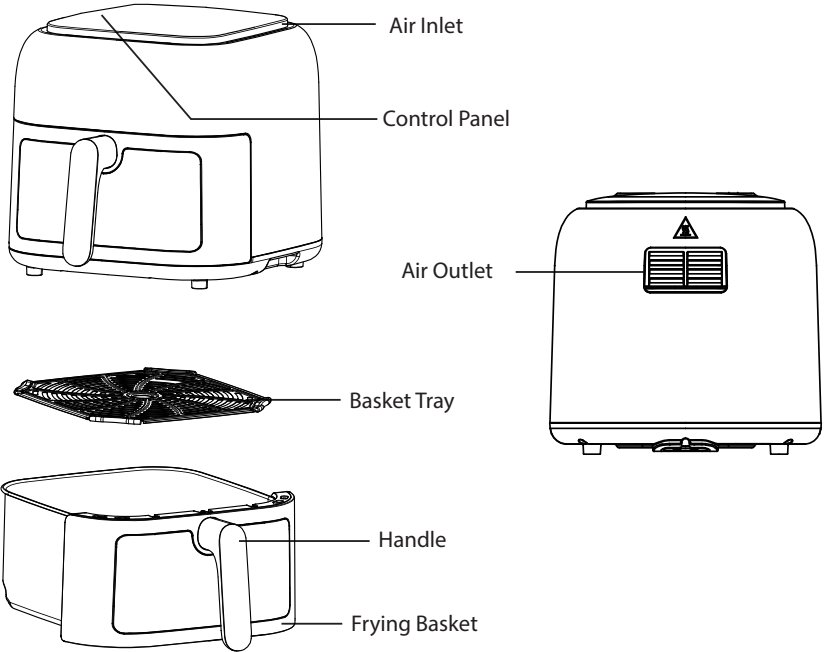

Control Panel

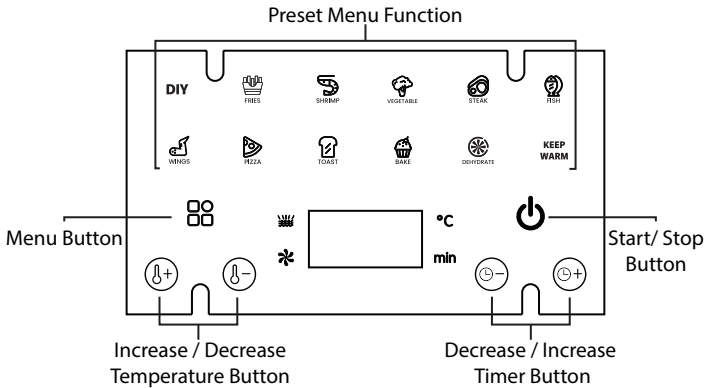



CONTROLS AND OPERATIONS

The air fryer can be used to prepare a large range of ingredients. Refer to page 6 and 7 for some tips and guide on using the air fryer.

Steps:

1. Plug in the power plug to a grounded socket. When the power is turned on, the digital screen and all indicator lights will flash once, and only Menu “” Button will light up on the control panel there after.
2. Carefully pull the handle of the air fryer. Prepare the basket and desired food.
3. Insert the tray into the basket. Push down to ensure it is secure and in a levelled position. There should be a small amount of space between the tray and bottom of the basket.
Note: Using the air fryer with the tray in place allows for maximum amount air circulation, which promotes even cooking and crispiness.
4. Put the ingredients into the frying basket.
Note: Never fill the frying basket more than 3/4 of the basket, as this could affect the quality of the end result.
5. Slide the frying basket back into the air fryer.
Note: Never use the frying basket without the basket tray in it.

Warning: Do not directly touch the air fryer basket during and right after use, as it gets very hot. Only hold handle of the air fryer basket.

6. Press the Menu “” Button. All indicator lights and digital screen light up, enter into standby mode.
7. Select the Preset Menu Function according to the food you are cooking by pressing the Menu “” Button. If required, you may select and adjust your temperature and cooking time by pressing the temperature and timer button.
8. Press the Increase / Decrease Temperature Button to adjust to your desired temperature. Each press changes the temperature by 5°C, with an adjustable range of 60°C - 200°C. Press and hold the button to adjust the temperature rapidly.
9. Press the Increase / Decrease Timer Button to adjust according to your desired cooking time. Each press changes the time by 1 minute, with an adjustable range of is 1 to 60 minutes. Press and hold the button to adjust the timer rapidly.

Note: For Dehydrate function, each press adjusts the time by 5 minutes, with a range of 30 to 480 minutes. For Keep Warm function, the range is 1 to 120 minutes.

10. After selecting all cooking settings, press the Start / Stop “” button and the air fryer will start cooking.

Note:

- The time and temperature can be adjusted halfway through cooking.
 - If the air fryer is used immediately when switched on, add 3 minutes more to the preparation time. Alternatively, preheat the appliance without any ingredients for about 4 minutes.
 - Some ingredients require shaking or turning over halfway through the preparation time. To shake or turn over the ingredients, pull the air fryer basket out of the appliance by the handle and shake it or turn over the ingredients with a fork (or tongs). Then put the air fryer basket back.
11. The air fryer will beep 5 times when the cooking has finish, but its fan continues to operate for approximately 1 minute until the internal temperature drops.
 12. To turn off the air fryer earlier than set cooking time, press the Start/ Stop button, and the display will show "----". The appliance will take about 1 minute to cool off and then turn off by itself. The air fryer will beep again once it turns off by itself.
 13. Pull the frying basket out of the air fryer and place it on a heat-resistant surface. Check if the ingredients are cooked. If not, slide the basket back into the air fryer and set the timer to a few more minutes, once completed use a fork (or tongs) to take out the ingredients. Empty the frying basket into a bowl or onto a plate.

Note: Do not overturn the frying basket, as this will cause the redundant oil collected at the bottom of the frying pan to leak onto the food ingredients.

14. After using the appliance, turn off and unplug the main socket to power off the appliance.

Note:











- The appliance will not work until it is fully closed.
- Do not touch the frying basket during and after use, as it is hot after frying, only hold the frying basket by the handle.
- After hot air frying, the basket tray, the frying basket and the cooked foods are hot. Extreme caution must be used when handling the hot frying basket / basket tray.

This table below helps you to select the basic settings for the ingredients you want to prepare.

Note: Keep in mind that these settings are just a general guideline. Actual cooking timing may vary by the different types of food. E.g. size and quantity of food, thickness of meat.

There is no guarantee on the best setting for your ingredients.

Cooking Information Guide

| Preset Menu | Default Temperature (°C) | Default Time (MIN) | Temperature Range (°C) | Time Range (MIN) |
|--|--------------------------|--------------------|------------------------|------------------|
| DIY | 200°C | 10min | 60 - 200°C | 1 - 60 |
|  FRIES | 200°C | 15min | | |
|  SHRIMP | 180°C | 10min | | |
|  VEGETABLE | 180°C | 15min | | |
|  STEAK | 200°C | 20min | | |
|  FISH | 200°C | 20min | | |
|  WINGS | 200°C | 10min | | |
|  PIZZA | 180°C | 12min | | |
|  TOAST | 160°C | 5min | | |
|  BAKE | 160°C | 18min | | |
|  DEHYDRATE | 50°C | 360min | | |
| KEEP WARM | 80°C | 30min | 60 - 100°C | 1 - 120 |

Tips for cooking

1. Smaller ingredients usually require a slightly shorter preparation time than bigger ingredients.
2. A larger amount of ingredients requires a slightly longer preparation time, while a smaller amount of ingredients requires a slightly shorter preparation time.
3. Foods cook best and most evenly when they are of similar size and thickness.
4. Shaking smaller ingredients halfway through the preparation time optimises the end result and can help prevent uneven fried ingredients.
5. For best results, arrange food on the tray in a single layer.
6. When air frying fresh vegetables, make sure to pat them dry completely before tossing with oil and air frying to ensure maximum crispiness.
7. Add some oil on to fresh potatoes for a crispy result. Fry your ingredients in the air fryer within a few minutes after you added the oil.
8. Do not prepare extremely greasy ingredients such as sausages in the air fryer.
9. Snacks that can be prepared in an oven can also be prepared in the air fryer.
10. When air frying battered food, stick to thick, pasty batters. Thin batters, such as the batters use to make tempura, will run and not set fast enough like they do in a deep fryer.
11. Coating battered foods in panko (Japanese-style breadcrumbs) or puffed rice, and then spraying them with oil, helps create crispy, healthier versions of your favourite fried foods. Use pre-made dough to prepare filled snacks quickly and easily. Pre-made dough also requires a shorter preparation time than home-made dough.
12. You can also use the air fryer to reheat ingredients. To reheat ingredients, set the temperature to 150°C for up to 10 minutes.

CLEANING AND MAINTENANCE

- Clean the air fryer after every use and before storage.
- Unplug the air fryer from the power socket, remove the frying basket, and allow the appliance fully cool down.
- Wipe the outside of the air fryer with a damp cloth.
- Do not use metal utensils or abrasive cleaning material to clean them.
- Clean the frying basket and basket tray with hot water, some washing-up liquid and a non-abrasive sponge. If dirt is stuck, fill the frying basket with hot water with some dish-washing liquid and soak for approximately 10 minutes.
- Use a damp cloth or a cleaning brush to remove food residues from the inside of the air fryer cavity and the heating element after the appliance has fully cooled down.
- Make sure all the parts are clean and dry thoroughly before storage.
- Never store the air fryer when it is hot or damp.
- Store the air fryer in its box or in a clean and dry place.
- The air frying basket and basket tray are dishwasher safe.

Note: If dirt is stuck to the basket tray, or the bottom of the frying basket, fill the frying basket with hot water with some washing-up liquid. Put the basket tray in the frying basket and let them soak for approximately 10 minutes.

TROUBLESHOOTING

| Problem | Cause of Issue | Solution |
|--|---|---|
| The appliance does not work. | The appliance is not plugged in. | Plug in the appliance into a main socket. |
| | The timer has not been set. | Turn the timer knob to the desired time to switch on the appliance. |
| The ingredients are not fully cooked. | The amount of ingredients being cooked is too much. | Place smaller amount of the ingredients at one time. |
| | The set temperature is too low. | Turn the temperature control knob to the required temperature setting. |
| | The set time is too short. | Turn the timer knob to the required cooking time. |
| The ingredients are not evenly cooked. | Certain types of ingredients need to be turned over halfway during the cooking. | Halfway of the cooking time, pull open the basket to pause the appliance, carefully turn the food over, then put back the frying basket into the appliance to continue cooking the food with the same recipe and temperature with the remaining 1/2 time. |
| When white smoke comes out of the appliance. | It is normal for white smoke to appear when prepping greasy ingredients. | When cooking greasy ingredients in the appliance, some oils will leak onto the basket tray. The oil produces white smoke and the tray may heat up more than usual. This does not affect the appliance or the end result. |
| | The basket tray has grease residues. | Please make sure the air fryer basket and basket tray is thoroughly cleaned after every use. |
| French fries not crispy. | It depends on the water and oil content of ingredients. | Make sure the fries are dry before frying and do not cut the fries too thick. You can preheat the frying basket before frying. |
| Cannot slide the basket into the appliance properly. | There are too many ingredients in the basket. | Do not fill the basket exceeding the MAX indicator. |

| Problem | Cause of Issue | Solution |
|--------------------------|--|---|
| French fries not crispy. | It depends on the water and oil content of ingredients. | Make sure the fries are dry before frying and don't cut the fries too thick. You can preheat the glass basket before frying. |
| Display "E1". | There is an open circuit. | Please contact the Service Centre for repair |
| Display "E2". | There is a short circuit. | Please contact the Service Centre for repair. |
| Display "E3". | The temperature inside the air fryer is too high and extremely hot, activating the overheating protection feature. | Disconnect the power, pull out the glass basket and wait for the appliance to fully cool down before turning it back on to use again. |